

25 Light LED Arrow Board (Horizontal Arrow Board)

Our 25 Light LED Arrow Boards are used extensively on Level One roads in both mobile and static operations. They are simple to install, easy to operate and are fully compliant to NZTA CoPTTM specifications. They feature a robust aluminium housing, LED lamps with automatic / manual lamp dimming and a user-friendly in-cab controller.

*** Increased Visibility**

*** NZTA CoPTTM Compliant**

*** Improved Safety**



Indicative Design Only

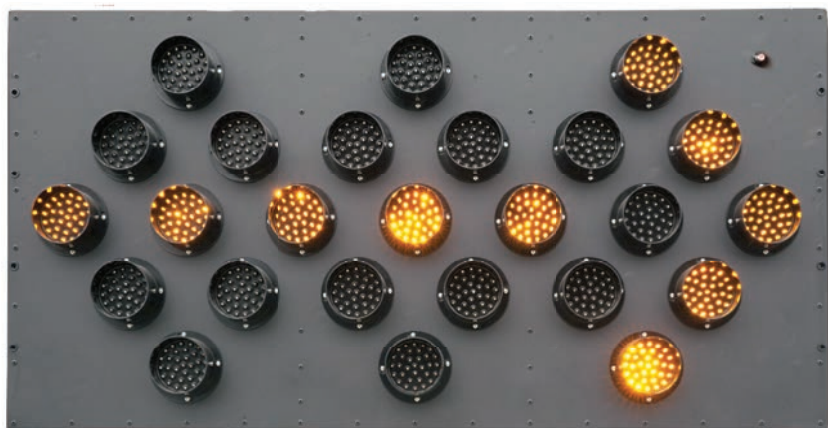

Package includes: 25 Light LED Arrow Board, in-cab controller, 15m data cable and a 5m power cable.

Features & Benefits

- NZTA CoPTTM compliant
- LED lamps with sun visors
- Push buttons with back lighting
- Quick & easy installation
- Automatic / manual lamp dimming
- Pre-programmed arrow configurations
- Dual voltage - 12v / 24v
- Light weight aluminium housing
- Brightness & low battery Indicator

Key Features



In Cab Controller

The controller provides real time information of the Arrow Board mode and LED brightness.

It is generally installed within reach of the driver/operator for ease of use and visibility.



LED Lamps

Our Arrow Board features 25x high intensity LED Lamps. LEDs uses less power up to 85% less than halogen.

The intensity or brightness of the LEDs is automatically or manually adjusted via the in-cab controller.

RTL Product:

25 Lamp Arrow Board LED 12/24V

Stock code:

ET ABVA15B25

Placing an Order:

For ease of ordering, please mention the RTL 25 Light LED Arrow Board and reference stock code above.

25 Light LED Arrow Boards: Providing additional safety in workzones

Specifications & Upgrades

Dimensions

Back of the Arrow Board

Please note, the external box shown on the drawing must be taken in to consideration when building the truck and framework etc

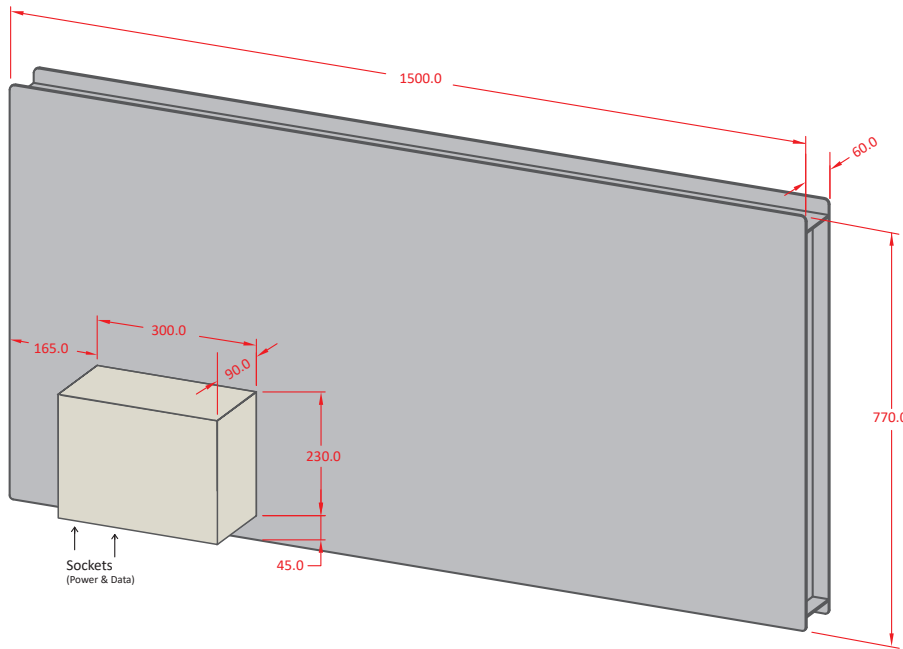

Front of the Arrow Board: Light Sensor (Top Right)

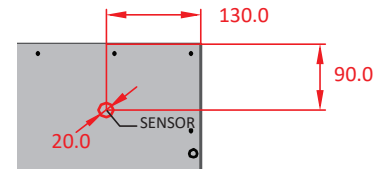

Specifications

Width:	1500mm
Height:	770mm
Arrow Board Depth:	60mm (excluding lamps and enclosure)
Enclosure Depth:	90mm
Weight:	30kg
Housing / Finish:	Black powder coated aluminium
Fixings:	8 front & 8 back M8 rivnuts (bolts excluded)
Solid state circuitry:	Yes
Short circuit protected output circuitry:	Yes
Number of Lamps:	25 (per Arrow Board)
Number of LEDs	50 LEDs (per lamp)
Lens Diameter:	100mm
Flashing Rate:	60 times/min (0.4sec ON, 0.6sec OFF)
Voltage:	12/24v dual voltage
Brightness:	Manual or automatic (7 levels)
Light Sensor Location:	Front / Top Right of the Board
Control:	Push button
Visual Display Indicator:	Yes
Battery Indicator:	Yes (low voltage only)
Wireless Option:	No
Cables:	- Data Cable - 15 metres - Power Cable - 5 metres

Reflective Surround Upgrade



Indicative Design Only

RTL have experienced staff that can apply the red and white reflective chevron / surround and the TV4 PASS WITH CARE sign overlay to the rear of your Level One traffic management truck.

This service is available at our Auckland, Christchurch and Invercargill branches. Call us today on 0800 785 744 for information including pricing and bookings.