



# **Scorpion II<sup>®</sup> Truck Mounted Attenuator Assembly Manual and Mounting Instruction Guide**

**For Model:**

**Scorpion II<sup>®</sup> Model C MASH TL-3 TMA  
(Excludes high reach extension)**

**PLEASE READ ALL INSTRUCTIONS CAREFULLY  
BEFORE PROCEEDING WITH THE INSTALLATION**

Version 1.0

# Scorpion II® Truck Mounted Attenuator Assembly Manual and Mounting Instruction Guide

(For Model: Scorpion II® Series 10000 TMA)

This Manual is Available at [www.traffixdevices.com](http://www.traffixdevices.com)

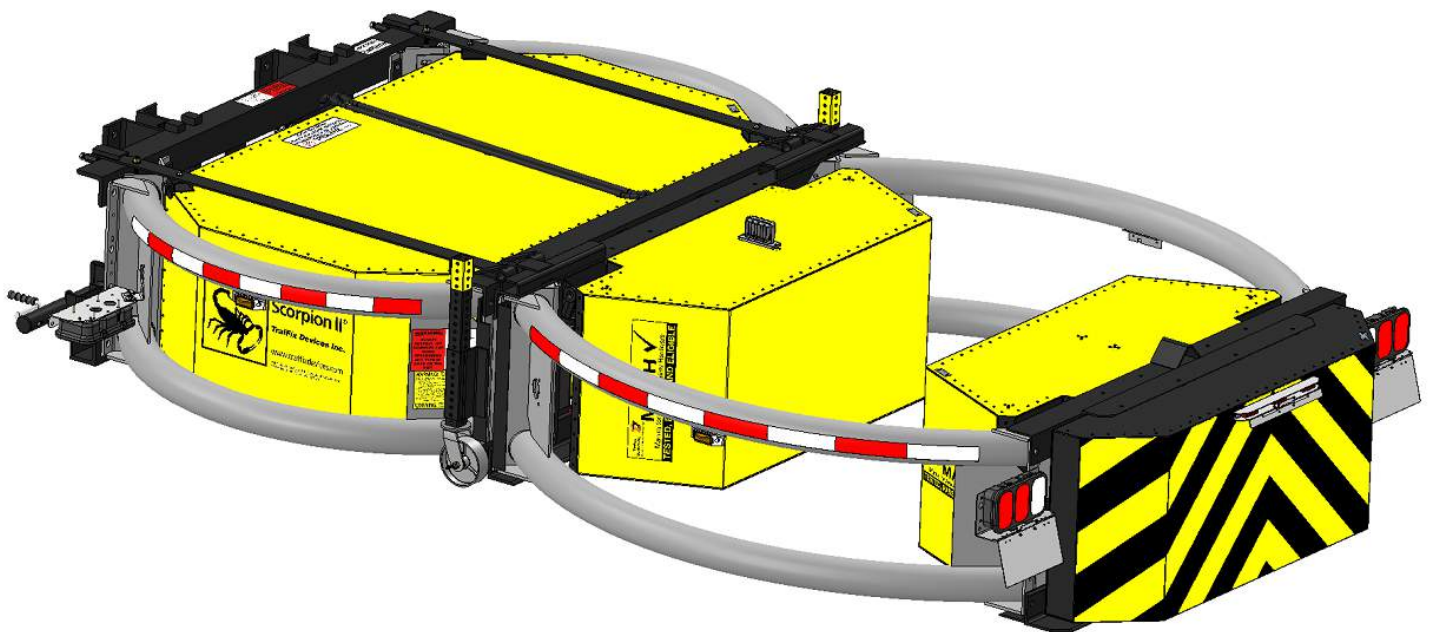

160 Avenida La Pata  
San Clemente, CA 92673

**This Page is Intentionally Left Blank**

# Scorpion II® 10000 TMA

## Introduction to Assembly and Mounting Instruction Guide



160 Avenida La Pata

San Clemente, CA 92673

[www.traffixdevices.com](http://www.traffixdevices.com) [orders@traffixdevices.com](mailto:orders@traffixdevices.com)



**Important:** These instructions pertain only to the assembly and mounting of the Scorpion II 10000 Truck Mounted Attenuator (TMA) Model C TL-3. These instructions are only for the assembly of the models and/or accessories cited in each section. Any deviation from the models and accessories shown would require consultation with the appropriate highway authority engineer and/or certified TrafFix Devices, Inc. representatives. Contact information of these representatives can be found on the last page of this manual (Pg.63).

Proper Installation of the Scorpion II Truck Mounted Attenuator (TMA) is essential for proper performance of the system. For this reason, contacting a TrafFix Devices, Inc. Certified Attenuator Installer for assistance in mounting the system is recommended. Contact TrafFix Devices, Inc. to obtain a list of Certified Installers in the area. Please read this manual in its entirety before assembling, installing, or operating the Scorpion II TMA. The information in this Manual supersedes all previous versions and manuals, with updated illustrations and other information available at time of printing; however; TrafFix Devices, Inc. reserves the right to make changes at any time. **For any questions on proper Installation and Operation of the Scorpion, please contact us at (949) 361-5663.**



**Important:** This manual applies to the Scorpion II® Truck Mounted Attenuator by TrafFix Devices, Inc. It pertains only to the models referenced herein. It requires that all Assembly, Mounting, Service and Repair parts be Genuine Scorpion parts that have not been modified or repaired from the original in any way, unless with prior knowledge, consultation and approval by TrafFix Devices, Inc. Engineering.

# Table of Contents

	Page
<b>Section 1</b>	
Limitations and Warnings .....	1
Operating Instructions.....	2-3
Safety Instructions & Precautions.....	4
Notes.....	5
TMA Model C Parts List- Major Components.....	6-7
<b>Section 2</b>	
Assembly of TMA Model C.....	8
Pre-Assembly Checklist/Scorpion II Registration.....	9
Remove Packaging/Tail Light & Side Marker Light Inspection.....	10-11
Recommended* Assembly Tools.....	12
Strut Assembly.....	13-17
Cartridge Assembly.....	18-20
TMA Model C: Strut to Cartridge Assembly.....	21-28
Hydraulic Pump Assembly/Parts List.....	29-30
<b>Section 4</b>	
Standard Truck Mounting Installation.....	31
Standard Flatbed Truck Mounting Installation.....	32-36
Dump Truck Mounting Installation.....	37-40
Installing the Fast-Trak SwiftConnect™ to the TMA.....	41
Fast-Trak SwiftConnect™ Configuration 1.....	42-43
Fast-Trak SwiftConnect™ Configuration 2.....	44
Fast-Trak SwiftConnect™ Configuration 3.....	45
Fast-Trak SwiftConnect™ Step-by-Step Mounting Process.....	46
<b>Section 5</b>	
Support Post Installation.....	47
Flat Bed Side Support Installation.....	48-52
Center Support Installation.....	53-55
Dump Truck Side Support Installation.....	56-60
<b>Section 6</b>	
Limited TMA Warranty/ Notes.....	61-62
TraFFix Devices, Inc. Contact Information.....	63

# Limitation and Warnings

TraFFix Devices Inc. (TDI), in compliance with the Manual for Assessing Safety Hardware (MASH) recommended procedures for the Safety Performance of Highway Features. TDI contracts with ISO accredited testing facilities to conduct crash tests, evaluation of tests, and submittal of results to the Federal Highway Administration for Eligibility for Federal-Aid Reimbursement. The Scorpion II Truck Mounted Attenuator (TMA) system was tested to meet the safety evaluation guidelines of MASH. The Scorpion II has been tested at TL-3 (62.1 mph/ 100 km/hr) speed impact conditions. These tests are intended to evaluate product performance by simulating those impacts outlined by MASH involving a range of vehicles on the roadways, from cars with an approx. weight of 2425 lbs [1100 kg] to trucks with an approx. weight of 5004 lbs [2270 kg]. The Model C TMA is a TL-3 tested device capable of decelerating and stopping the light and heavy weight vehicles 2425 lbs [1100 kg] and 5004 lbs [2270 kg] in accordance with the criteria of Tests 3-50, 3-51, 3-52, and 3-53 for TL-3 (62.1 mph/ 100 km/hr) FHWA Eligibility. Reference FHWA Eligibility letter CC-132. Additionally, the Scorpion II TMA was tested to meet the requirements of TD 49/07. These tests are based on the Requirements for Lorry Mounted Crash Cushions from the Highways England Road Ministry. The Scorpion II TMA is accepted for various speed levels as shown in TL3.UK: 110 km/h [68.3 mph]. These specified tests are not intended to represent the systems performance when impacted by every vehicle type or every impact condition existing on the roadway. This system is tested only to the test matrix criteria of MASH and TD 49 UK. Traffix Devices does not represent nor warrant that the results of these controlled tests show that vehicle impacts with the products in other conditions would necessarily avoid injury to person(s) or property. Impacts that exceed the system's specifications may not result in acceptable crash performance as outlined in MASH; relative to structural adequacy, occupant risk, and vehicle trajectory. TDI expressly disclaims any warrant or liability for injury or damage to person(s) or property resulting from any impact, collision, or harmful contact with products, other vehicles, or nearby hazards or objects by any vehicle, object or person, whether or not the products were installed by third parties. The Scorpion II TMA system is intended to be assembled, delineated, and maintained in accordance with specific State and Federal guidelines. TDI offers a reflective delineator panel for its TMA line of products. However, the material is only intended to supplement delineation required by the Department of Transportation's "Manual on Uniform Traffic Control Devices" (MUTCD). The appropriate highway authority approved engineer should be careful to properly select, assemble, and maintain the product. Careful evaluation of the speed, traffic direction, and visibility are some of the elements that require evaluation for the proper selection of a safety appurtenance by the appropriate specifying highway authority.

# Operating Instructions

Proper Operation includes knowledge of TMA use in Work Zones, both Moving and Stationary, including the proper spacing, to allow for “roll-ahead”. Before use, the Operator should have prior knowledge/discussion of the Work Zone in which the TMA will be deployed and that the TMA model used has been tested to Test Level 3 = 100 kph/62 mph. TMA’s should only be operated by individuals properly trained in their use in work zones.

## Pre-Use Inspection

1. Walk around the unit inspecting for damaged, loose, or missing bolts, pins, cotter pins and safety snaps.
2. Inspect for damage to the energy absorbing modules and aluminum tubes, checking for deep gouges, deep scratches, warping, or cracking.
3. Inspect the steel structure for damage, looking for warping, cracks, breaks or other damage.
4. Inspect all lights for proper operation (including arrow/message board if applicable).
5. Cycle the unit from stowed to deployed and back to stowed position (see directions below), ensuring proper sequence and function (including arrow/message board lift system if attached) pay close attention for any binding or “slop” during operation and that the alarm is functioning properly.
6. Check road clearance of TMA in deployed mode, to ensure it is in specification (12 inches  $\pm$ 1 inch).
7. Ensure that retroreflective sheeting is in place and meets requirements for job.
8. When cycling the TMA up and down, check the lockout arm (between the cartridge and strut) for proper motion and alignment. When in the stowed position, the two pivoting sections of the lockout arm should form a straight line.
9. Check visually for hydraulic leaks.
10. Check to ensure that there are no loose items on the truck that can become a projectile during an impact.
11. Make sure items in the cab of the vehicle are secure and cannot come loose and become a projectile should an impact occur.
12. Adjust the headrest properly for the driver of the vehicle.
13. Any deficiencies should be corrected before use.

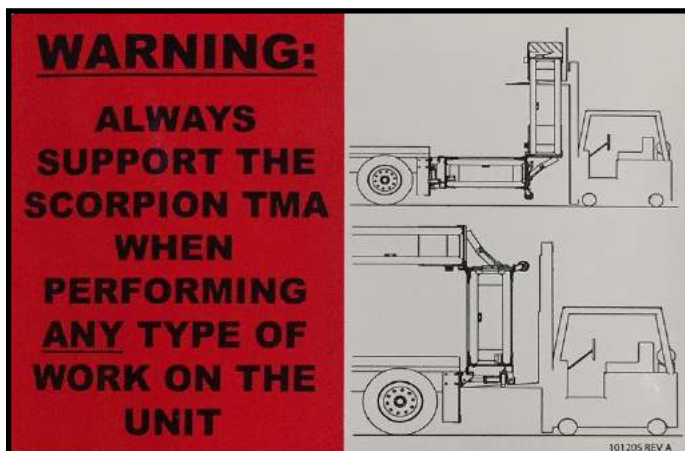

MUST BE FULLY POWERED DOWN FOR TRAVEL 0 TO 60 MPH



MUST BE FULLY POWERED DOWN FOR DEPLOYMENT 0 TO 30 MPH

## To Raise (“Store”) the Unit for Transport

1. Ensure that both the truck bed and area above the rear of the host vehicle is clear.
2. Locate the desired control box, either the in-cab controller (if installed) or the plug-in. If using the plug-in, and it is not already plugged in, plug it into the socket on the TMA near the rear passenger side of the truck.
3. Push the “Up” button on the chosen controller and hold until the unit makes contact with the support posts. **Be sure to avoid the pinch points around cartridge to strut hinge and the pivot point at the strut to truck connection. If an Arrow/Message Board Lift System is installed, be sure it cycles to the down position before the TMA raises.**
4. **Continue** to hold the Up button until the Scorpion slides forward 1-2 inches on the support post(s) and for 4 seconds after it has stopped moving. This ensures the hydraulic system is at the proper pressure to hold the TMA tight against the cradle which will save wear and tear or possible damage to the unit.
5. If the unit is to be transported, ensure that the drop jacks are fully retracted and pinned and that the swivel jacks are fully retracted and rotated to the stored and locked position.
6. If using the plug-in controller unplug and store in the cab.

## To Lower (“Deploy”) the Unit for removal or Use

1. Ensure that both the area above and to the rear of the host vehicle is clear.
2. Plug in the controller (see #2 above) **or** locate the in-cab controller (if installed).
3. If the unit is being removed, the swivel jacks should be rotated to the deployed position and the drop jacks lowered and pinned to the correct height. **If the unit is being deployed for use, all jacks should remain in the stored position.**
4. **Being careful to avoid the pinch points**, push the “Down” button until the TMA is fully unfolded and the rear box has stopped moving and the tail/ICC light covers have deployed.
5. **Continue** to hold the Down button for 4 more seconds after the Arrow/Message Board Lift System (if attached) or the TMA has stopped moving. This will ensure the TMA is fully deployed and the hydraulic system is at the proper pressure to hold it in position.
6. Make sure the Arrow/Message Board is displaying the proper message.

**Note:** TMA must be in the stowed position for travel to and from the Work Zone

**Important:** It is recommended that the unit not be deployed, used, or stowed for transport, while the host vehicle is travelling at speeds above 30 miles per hour. If your application makes this necessary, please see the “Severe Duty Note” in the “[Maintenance Intervals and Pre-Use Inspection](#)”. As described in the procedure above, always ensure the area above and to the rear of the bed of the truck is clear before deploying or stowing the Scorpion.



## SAFETY INSTRUCTIONS & PRECAUTIONS

- A. Before attempting to install or operate the Scorpion II 10000 Series Truck Mounted Attenuator (TMA) this manual should be read and understood. Those areas with warnings or cautions should be carefully followed.
- B. Before raising or lowering the TMA the operator should check that the area around the TMA is clear and that personnel are not in or near the area.
- C. Before operation on the roadway, check all 1" diameter pins and bolts at the back-up and hinge areas for tightness and excessive wear. Also, check that all cotter pins are in place.
- D. Check that the two drop jacks are fully retracted and that the safety pins are in place. Also, check that the crank jacks are fully retracted and rotated to the up and locked position.
- E. For correct operation of the TMA in the use mode (fully extended in the horizontal position), the TMA should be 12" ± 1" above the ground and horizontal to the roadway.
- F. The responsible agency for the truck should check that the following specifications are met: The truck should weigh a minimum of 15,000 lbs. If the truck is ballasted, the ballast should be properly anchored to the truck frame to prevent movement during an impact. The truck should be equipped with proper operator safety equipment such as seat belts, headrest, etc.
- G. Before disconnecting the TMA from the truck, make sure the TMA is in the horizontal position with all jack fully deployed

## Special Warnings

1. **After a vehicle impacts the TMA, do not drive the truck with the damaged TMA. Remove the TMA at the backup and have the TMA transported back to the maintenance yard.**
2. **Check the TMA model to make sure that the posted speed matches the TMA capacity.**

**Model C = TL-3 = 100 kph. (62 mph)**



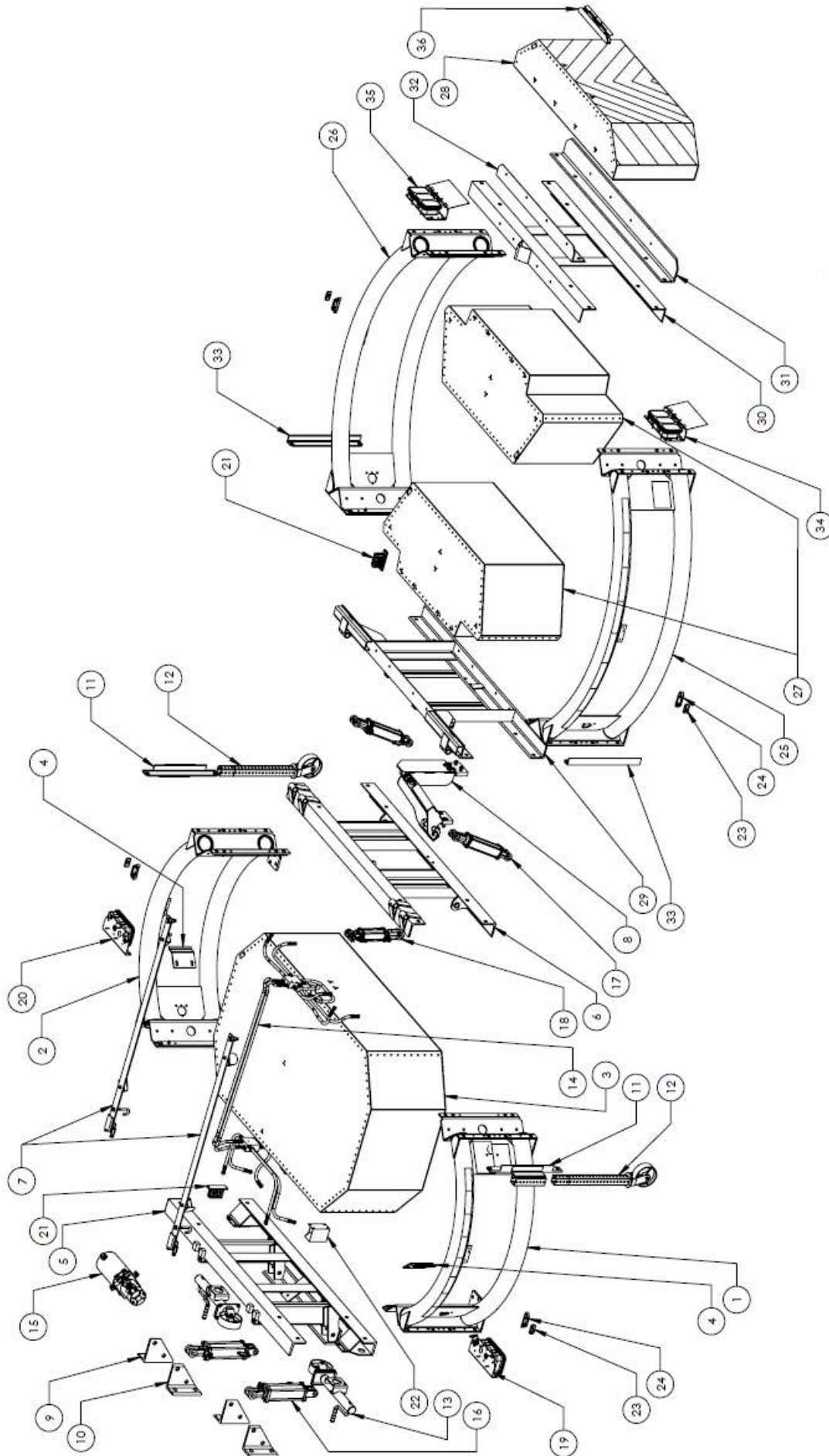

## Scorpion II Model C TL-3

## Major Components

### **Scorpion II 10000 TMA Model C Parts List - Major Components**

<b>Item #</b>	<b>Part #</b>	<b>Item Description</b>	<b>QTY/TMA</b>
1	10200TL-MASH-KIT	Strut Tube Assy, LH, Includes: C-Tape, Warning Labels, Side Marker Bracket Installed	1
2	10200TR-MASH-KIT	Strut Tube Assy, RH, Includes: C-Tape, Warning Labels, Side Marker Bracket Installed	1
3	11400D	Module D, Absorbing Scorpion II	1
4	10204	Energy Absorber Bracket	2
5	10300	Backup, Powder Coated Black	1
6	11300E	Rear Diaphragm, Strut, Powder Coated Black	1
7	10118	Tension Strap Set, Powder Coated Black, Includes Hardware	1
8	11800	Lockout Arm, Powder Coated Black, Includes Hinges and Hardware	1
9	10351	Hydraulic Bracket, RH	2
10	10352	Hydraulic Bracket, LH	2
11	10750	Drop Jack Bracket, Universal, Powder Coated Black	2
12	10725	Drop Jack w/ 6" Caster	2
13	10701MNJ	Heavy Duty Swivel Jack w/ 6" Caster	2
14	10600J	Hydraulic Hose Kit, Scorpion II	1
15	11010	Hydraulic Power Unit, 12V, Field Service Replacement	1
	11011	Hydraulic Power Unit, 24V, Field Service Replacement	1
16	11200A	Hydraulic Cylinder, 3" Bore, 8" Stroke, Fittings Installed	2
17	11617A	Hydraulic Cylinder, 2-1/2" Bore, 8" Stroke, Fittings Installed	2
18	11812A	Hydraulic Cylinder, 2" Bore, 4" Stroke, Fittings Installed	1
19	10508C-LED	Strut Tail Light Assy, LH, 10-30 Volt LED, Color Pattern: Red/Red/White	1
	10504C-LED-RYR	Strut Tail Light Assy, LH, 10-30 Volt LED, Color Pattern: Red/Amber/Red	
	10504C-LED-YRW	Strut Tail Light Assy, LH, 10-30 Volt LED, Color Pattern: Amber/Red/White	
20	10516C-LED	Strut Tail Light Assy, RH, 10-30 Volt LED, Color Pattern: Red/Red/White	1
	10505C-LED-RYR	Strut Tail Light Assy, RH, 10-30 Volt LED, Color Pattern: Red/Amber/Red	
	10505C-LED-YRW	Strut Tail Light Assy, RH, 10-30 Volt LED, Color Pattern: Amber/Red/White	
21	10518	Junction Block	2
22	10507C	Motion Alarm, 10-30 Volt	1
23	10573	Side Marker Light, Amber, 10-30 Volt LED	4
24	10520	Housing, Side Marker Light	4
25	10100L-MASH-KIT	Cartridge Tube Assy, LH, Includes: C-Tape, Warning Labels, Side Marker Bracket Installed	1
26	10100R-MASH-KIT	Cartridge Tube Assy, RH, Includes: C-Tape, Warning Labels, Side Marker Bracket Installed	1
27	11400C	Module C, Energy Absorbing, Scorpion II	2
28	10400A	Module A, Energy Absorbing, 4" Yellow Avery MVP Sheeting	1
29	11300F	Front Diaphragm, Cartridge, Powder Coated Black	1
30	11300H	Rear Diaphragm, Cartridge, Powder Coated Black	1
31	11327	Bottom Angle, Cartridge, Powder Coated Black	1
32	10465	Top Angle, Cartridge, Powder Coated Black	1
33	10122	Vertical Support Angle, Powder Coated Black	2
34	10508B-LED	Cartridge Tail Light Assy, LH, 10-30 Volt LED, Color Pattern: Red/Red/White	1
	10504B-LED-RYR	Cartridge Tail Light Assy, LH, 10-30 Volt LED, Color Pattern: Red/Amber/Red	
	10504B-LED-YRW	Cartridge Tail Light Assy, LH, 10-30 Volt LED, Color Pattern: Amber/Red/White	
35	10516B-LED	Cartridge Tail Light Assy, RH, 10-30 Volt LED, Color Pattern: Red/Red/White	1
	10505B-LED-RYR	Cartridge Tail Light Assy, RH, 10-30 Volt LED, Color Pattern: Red/Amber/Red	
	10505B-LED-YRW	Cartridge Tail Light Assy, RH, 10-30 Volt LED, Color Pattern: Amber/Red/White	
36	10500B	ICC Bar Light Assy w/ Cover Flap	1

## Assembly of TMA Model C



# Pre-Assembly Checklist

## Initial Inspection:

Compare the Packing List with the original order to ensure all items have been delivered. Should any damage be found, or any items missing, contact the freight company as well as a Traffix Devices representative as soon as possible.

## Scorpion II Registration

1. Once unpacked, ensure that the TMA Serial Number matches with the number shown on the Packing List and the pallet. Once confirmed that they are the same, record the Serial Number below with all the serialized components to retain for personal records. Traffix Devices, Inc. will require this Serial Number for any possible repairs, warranty claims, and maintenance records.

Identify Serial Number for Scorpion II Truck Mounted Attenuator: \_\_\_\_\_

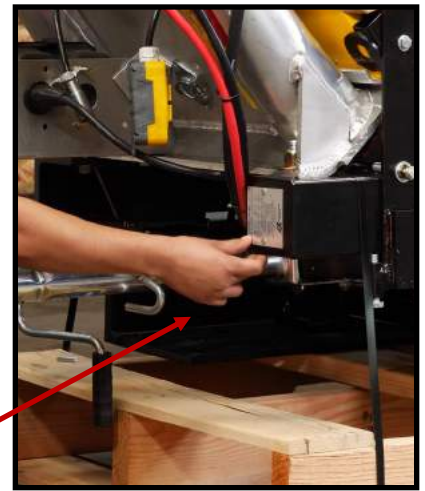

All Serial Numbers must coincide with each other

Module A Serial Number: \_\_\_\_\_

Module C Serial Number: \_\_\_\_\_

Module C Serial Number: \_\_\_\_\_

Module D Serial Number: \_\_\_\_\_

Module D  
Serial Number

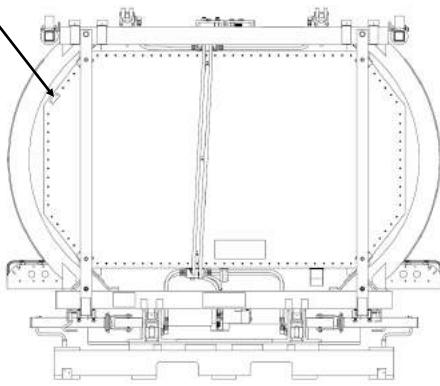

Strut Palletized



Sample of  
Module Serial Number

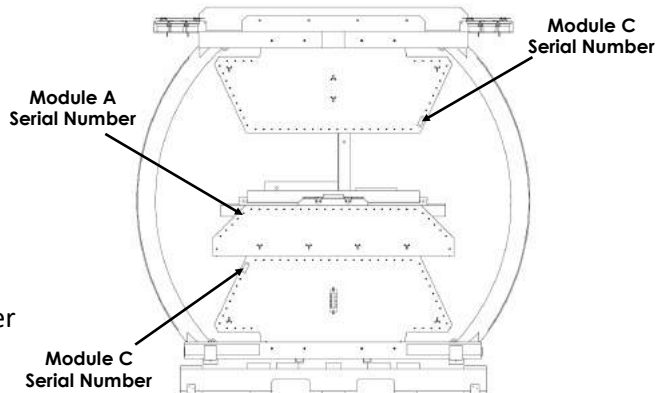

Cartridge Palletized

# Removing Packaging for Inspection

2. Observe the warning signs before unwrapping.



- Remove plastic wrap and cardboard with utility knife.



# Unwrap and Inspect: Tail Lighting and Side Marker Lights

- 3. Remove all cardboard from lights and inspect for damage.



BE CAREFUL



Side Marker:



Cartridge

Tail Lighting:



Strut

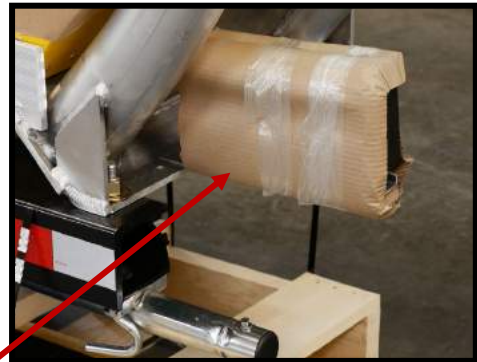



# TMA Model C (TL-3) Assembly

1. **IMPORTANT:** Before beginning Assembly, please read and review the Installation Section of this manual, paying close attention to the checklist at the beginning of the section.
2. Inspect the two pallets containing the Cartridge (right) and the Strut (left), shown in Figure 1, for shipping damage and completeness against the packing list. If there is anything missing or not complete, contact a Traffix Devices representative as soon as possible.
3. **WARNING: TOP HEAVY**– Indicates to move pallets with extreme caution. The use of a forklift is preferred when handling pallets. All personnel should be kept clear when the pallets are being moved.
4. Remove the shrink-wrap from the pallets using a utility knife. **Caution: Be careful not to cut any wires or parts!**

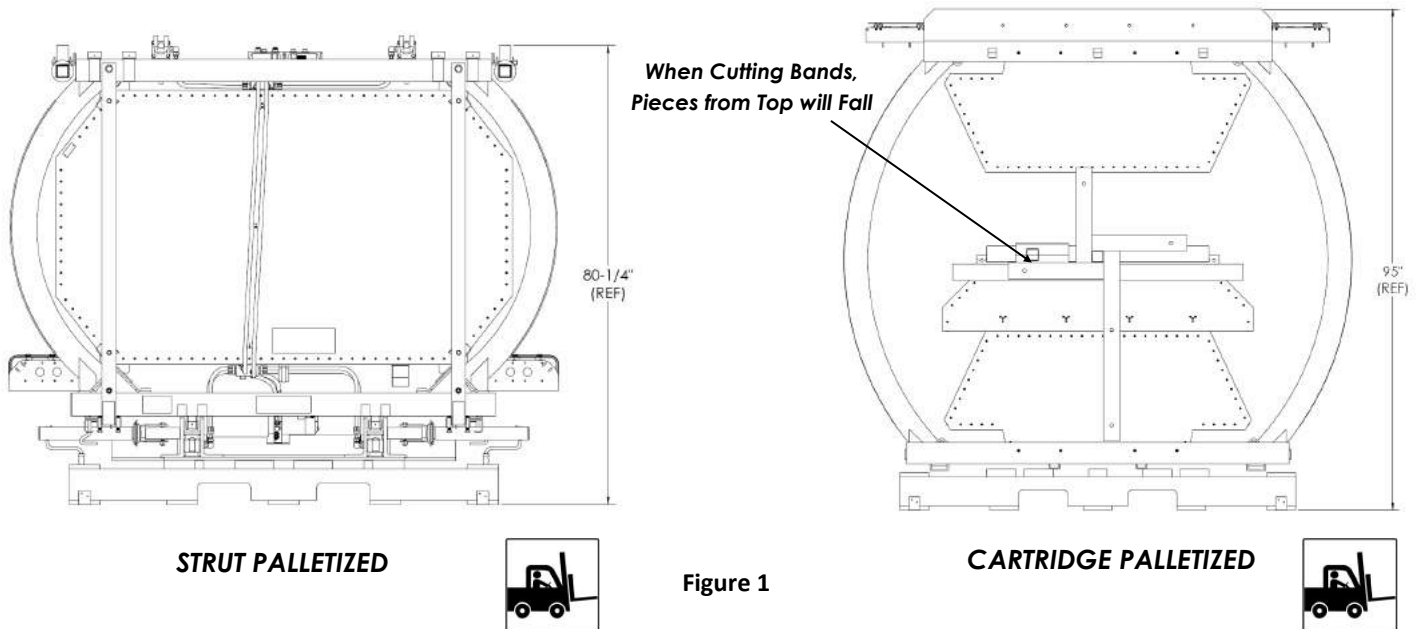

## Recommended\* Assembly Tools

1. Hammer
2. Tapered Pry Bar
3. Tape Measure
4. 12" Crescent Wrench
5. 1/2" Drive Socket Wrench
6. 1/2" Drive Socket (1-7/16")
7. Open End Wrenches (1-7/16", 3/4", 7/16")
8. 3/8" Drive Socket Wrench
9. 3/8" Drive Socket (7/16", 3/4")
10. Allen Wrench
11. Wire Cutter/Crimper
12. Floor Jacks or Stands (2 Ea.)
13. Forklift

\*More or less tools may be needed.

# Strut Assembly Overview



1. Remove the steel bands holding the Strut to the pallet.



2. Lift the Strut off the pallet using a forklift.
3. Remove mounting brackets from the pallet.



4. Reposition the Strut on the edge of the pallet.
5. Lower drop jacks so that the yellow paint is not showing.



6. Move the lifting straps towards the Back-up of the Strut and lift, using a forklift, until the unit is level.



7. Lower the swivel jacks so the Strut is no longer supported by the forklift.



8. Remove the clevis and hair pins from the hydraulic cylinder.

# Strut Assembly

1. Attach two (2) lifting straps to the Strut Diaphragm. The lifting straps must be positioned at an equal distance from the center to maintain stability when lifted. Each strap must have a minimum of 1500lb or greater load capacity. **WARNING: Do NOT tip the strut when attaching the lifting straps.**

Lifting Straps

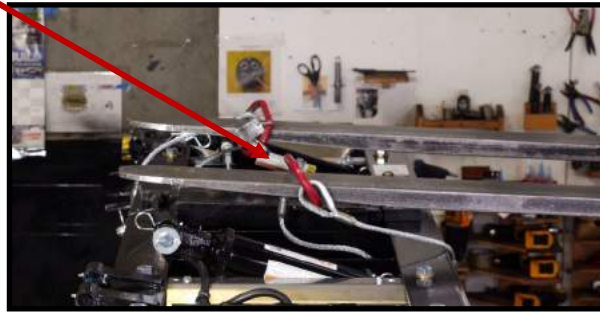

2. Cut and remove the steel bands that hold the Strut to the pallet.



Steel Bands

3. Using a forklift, lift the Strut off of the pallet. **CAUTION: Be sure the drop jacks are facing the forklift before lifting the strut.** Once the Strut is safely off of the pallet, remove the mounting brackets that are on the pallet.

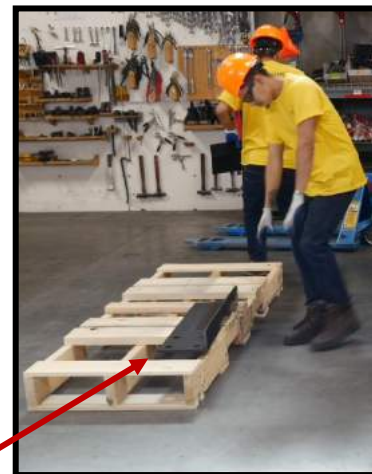

Mounting Brackets

# Strut Assembly

4. Position the strut on the edge of the pallet then slowly start lowering the Strut.



5. Once the drop jacks can safely be reached, do not lower the Strut any further. Do not let the lift straps slide off the forklift blades. Extend the drop jacks so that the yellow painted edge is aligned with the bottom of the drop jack mounting bracket. Secure the drop jacks in place with the safety snap. Continue to lower the strut until the drop jacks are stable on the ground.



# Strut Assembly

6. Remove the lifting straps from the Diaphragm and place them on the Back-up of the Strut. Lift the Strut until it is level.

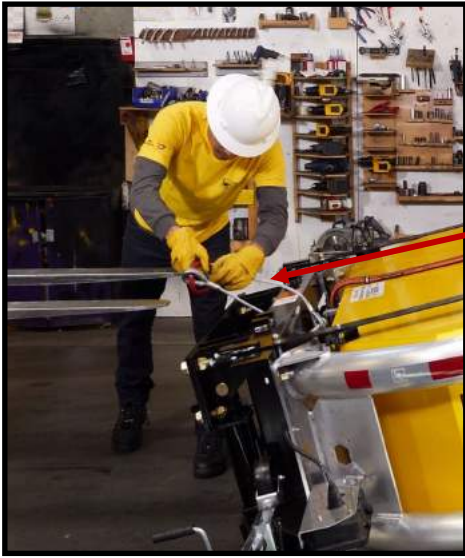

7. Rotate and lower the swivel jacks so that the Strut is level. The Strut should no longer be supported by the forklift once the swivel jacks are deployed.

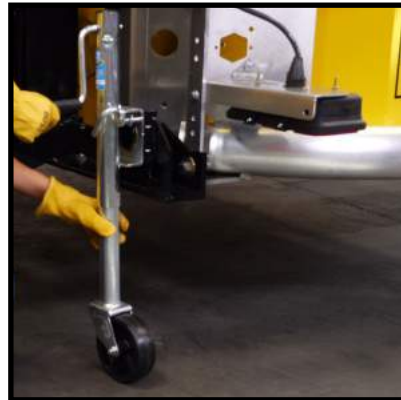

BE CAREFUL



# Strut Assembly

8. Cut and remove the zip ties that hold the hydraulic cylinders to the Strut. Remove the hair pins and clevis pins from both cylinders. **\*Clevis pins and hair pins are needed later on in assembly.** Once the hydraulic cylinders are free of the strut, grab the end of the cylinder and lift until the cylinder is fully extended.

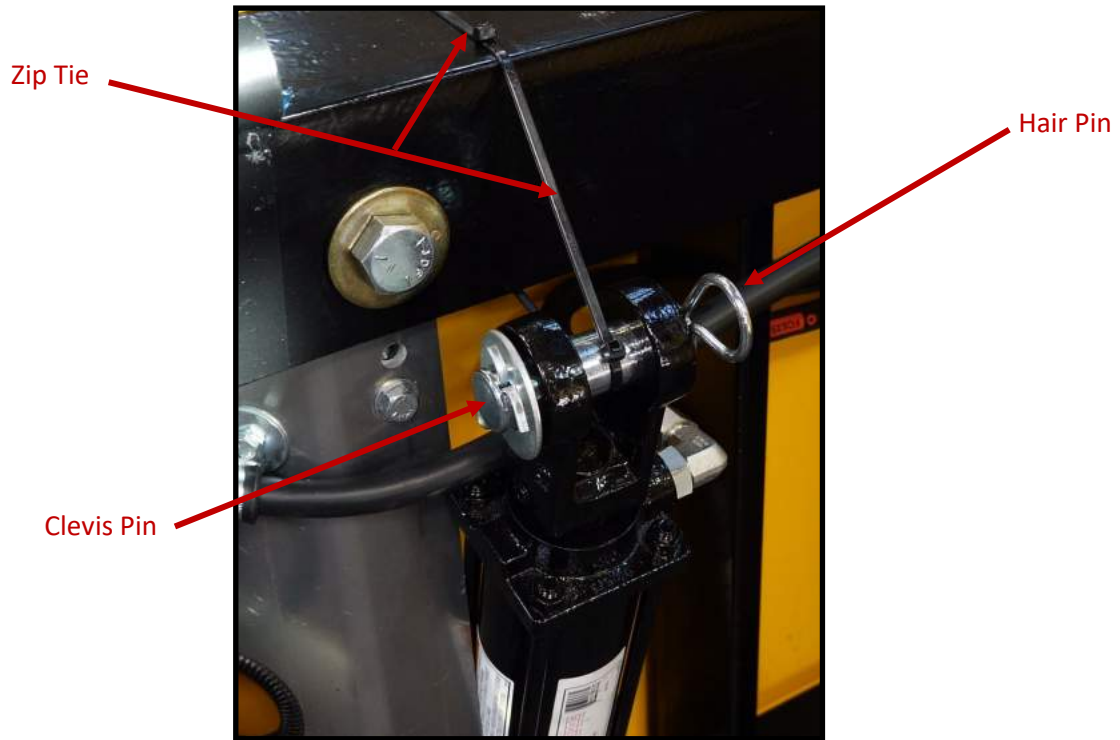

Hydraulic Cylinder

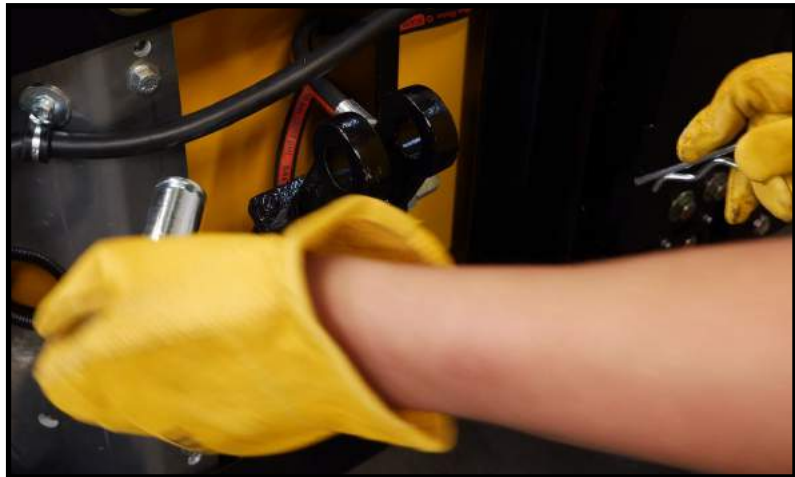

# Cartridge Assembly Overview



1. Cut and remove Steel bands and cardboard from the Cartridge.



2. Remove Module A.



3. Unbolt the junction box from Module C.



4. Remove Module C from the Cartridge frame.



5. Open parts box and confirm contents.

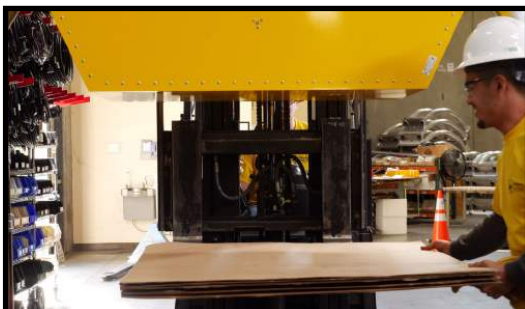

6. Place a piece of cardboard on the forklift to prevent damage to Module C.

# Cartridge Assembly

1. Cut the Steel bands that are holding the components to the Cartridge. One person should be holding the components in place, while another person cuts the bands. **WARNING: Watch for falling components when cutting the Steel Bands.** Remove the components and the cardboard from the Cartridge.



Safety Bands



2. Remove Module A from the Cartridge.

Module A



Module C

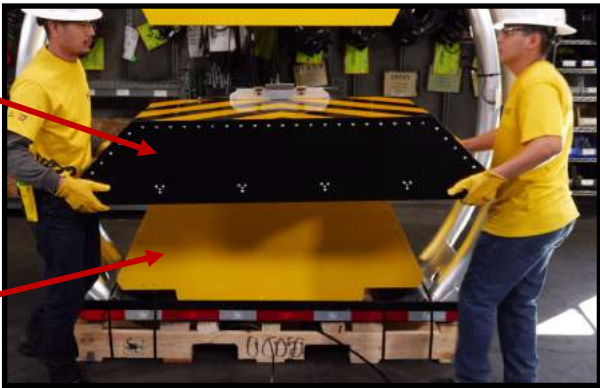

3. Unbolt the junction box and cables from Module C.

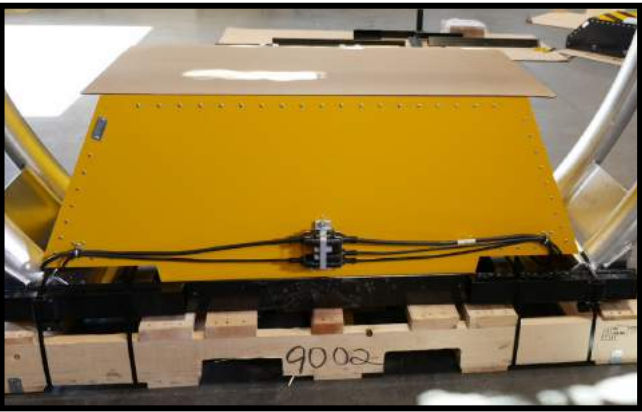



# Cartridge Assembly

4. Remove Module C from the Cartridge frame and set it aside for later use. Cut and remove the Steel bands that hold the Cartridge frame to the pallet.

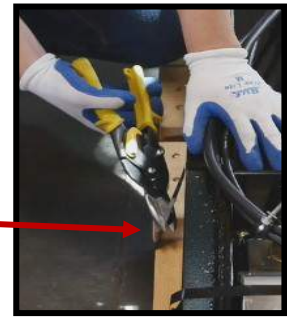

5. Open the parts box and confirm the contents. (If there are any parts missing, document it and inform a Traffix Devices Representative immediately.) Take out the two clevis pins and set them aside for later use.



Clevis Pins

6. To prevent paint on Module C from getting damaged, place a piece of cardboard on the blades of the forklift. Use the forklift to raise the Cartridge frame off of the pallet.

Module C

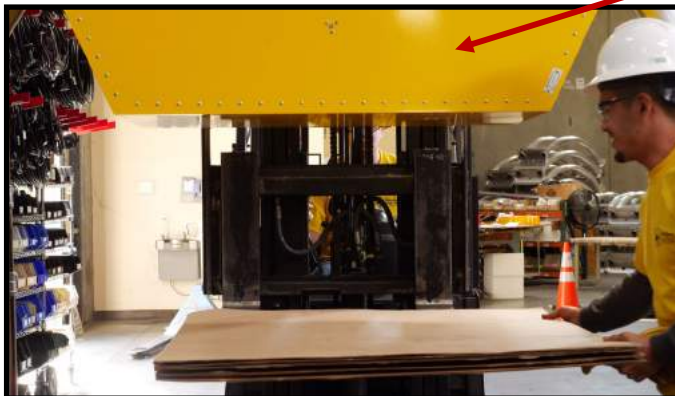

# TMA Model C: Strut to Cartridge Assembly Overview



1. With a forklift, align the hinges of the Cartridge to the hinges of the Strut.
2. Connect the Strut and Cartridge using hinge pins, with washers.



3. Secure hydraulic cylinders.



4. Attach the lockout arm.



5. Lower the Cartridge.



6. Install Module C.



7. Secure junction box, clamp, and connecting power cable.



8. Install Module A.
9. Install the ICC Bar Light Cable.

# TMA Model C: Strut to Cartridge Assembly

1. Cut zip tie holding the power cable that is attached to the Strut. Set the power cable aside for later use.



2. Insert the clevis pin, with a washer, into the hinges connecting the Strut to the Cartridge. Tap the pin into position if necessary. Secure the clevis pin with a cotter pin.



# TMA Model C: Strut to Cartridge Assembly

3. Secure the hydraulic cylinders to the Cartridge frame using the clevis pins. Secure the clevis pins with hair pins.

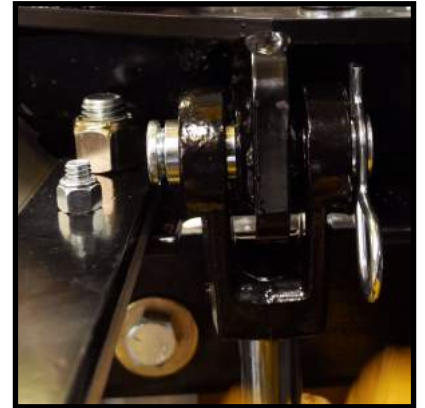
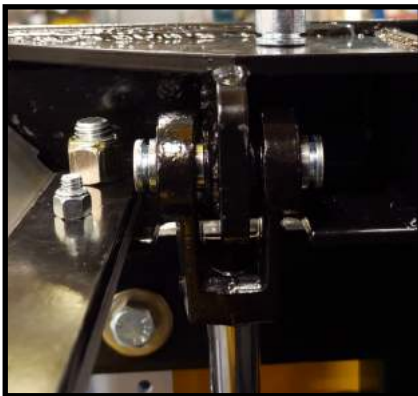
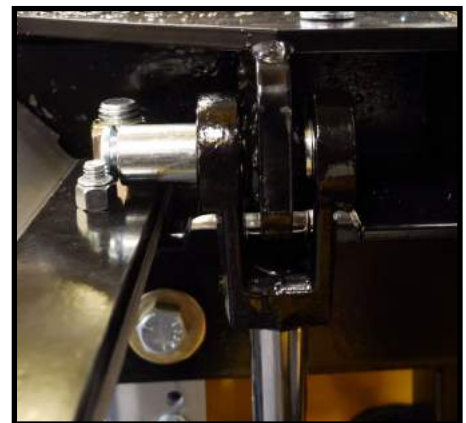

# TMA Model C: Strut to Cartridge Assembly

4. Bolt the lockout arm on the Strut, with washers, to the Cartridge. Using an "impact gun", fasten the bolts to the Diaphragm up to 95 ft-lbs. To ensure the proper orientation of the bolts, the bolt heads must be visible on the Cartridge side.

Lock out Arm  
(attached to Strut)



BE CAREFUL

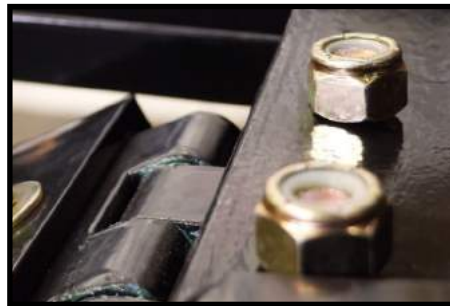
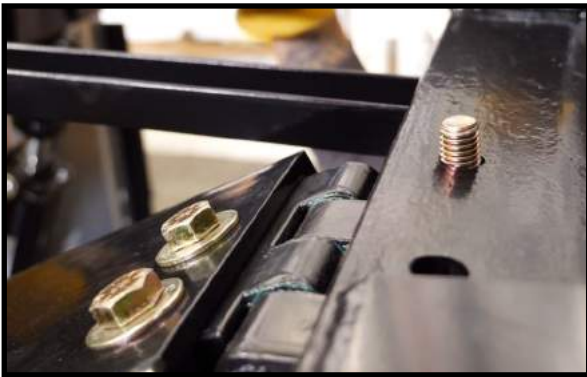

Lock out Arm Bolted  
Onto Cartridge

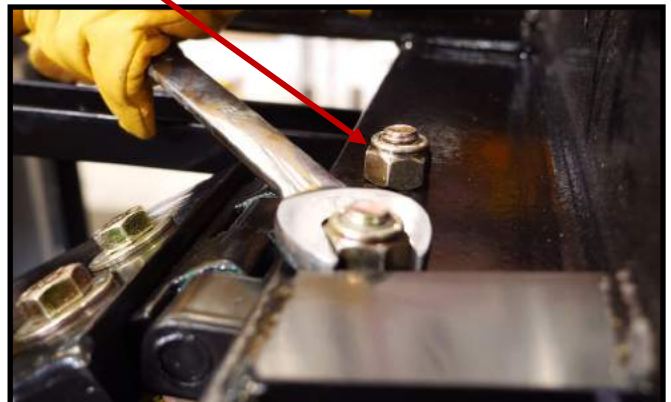
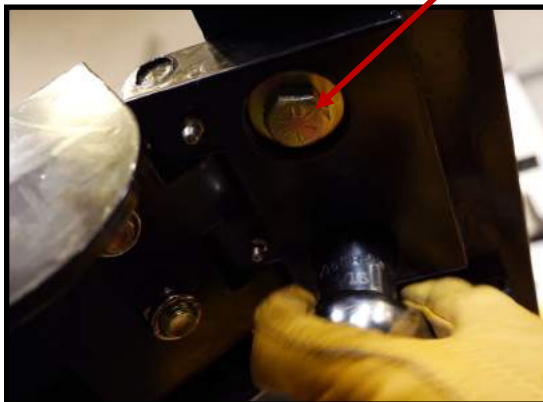

# TMA Model C: Strut to Cartridge Assembly

5. Slowly lower the Cartridge with the forklift until the TMA is level.

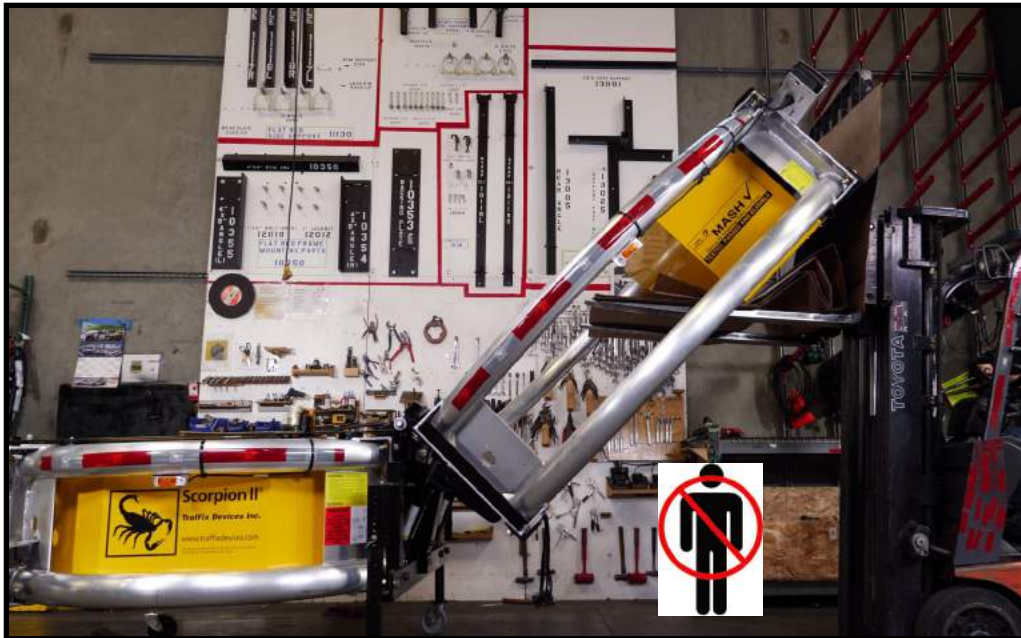

**CAUTION**  
TWO OR MORE  
PEOPLE OR A LIFTING  
DEVICE REQUIRED TO  
LIFT THIS ITEM



# Module C Installation

6. Install Module C.

A. Lift Module C into position on the Cartridge and secure with washers and Allen head bolts.

B. Use Threadlock adhesive on all bolts and tighten to a minimum of 20 ft-lbs.



7. Secure the junction box and bolt the clamp on top of Module C. Once secure, connect the power cable to the junction box.

Junction Box



Clamp



Power Cable



# Module A Installation

8. Install Module A.

- A. Lift Module A into position on the Cartridge and secure with bolts and washers.
- B. Use Threadlock adhesive on all bolts and tighten to a minimum of 20 ft-lbs.



9. Cut the zip tie that is holding the electrical cable and attach it to the cable that is located in the back of Module A. Secure the cables to the top of Module A using zip ties.

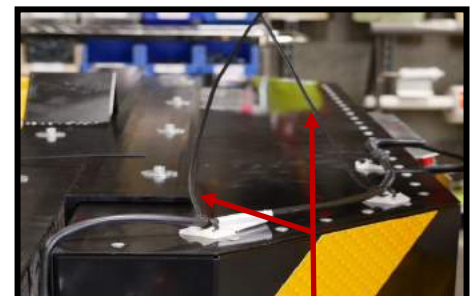
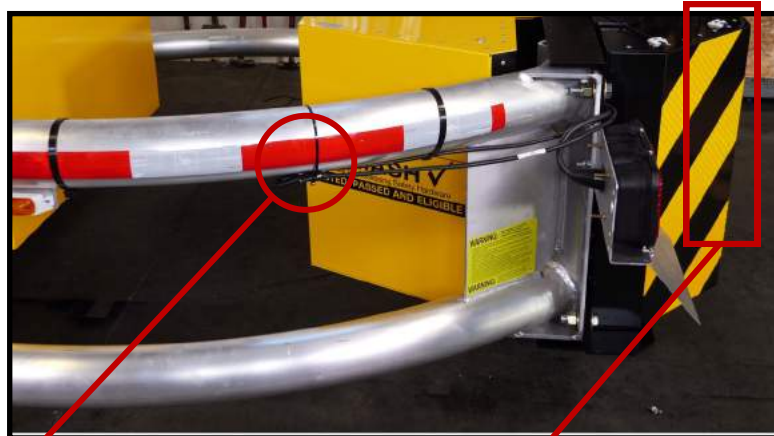

Zip ties





# Complete Assembly of Model C

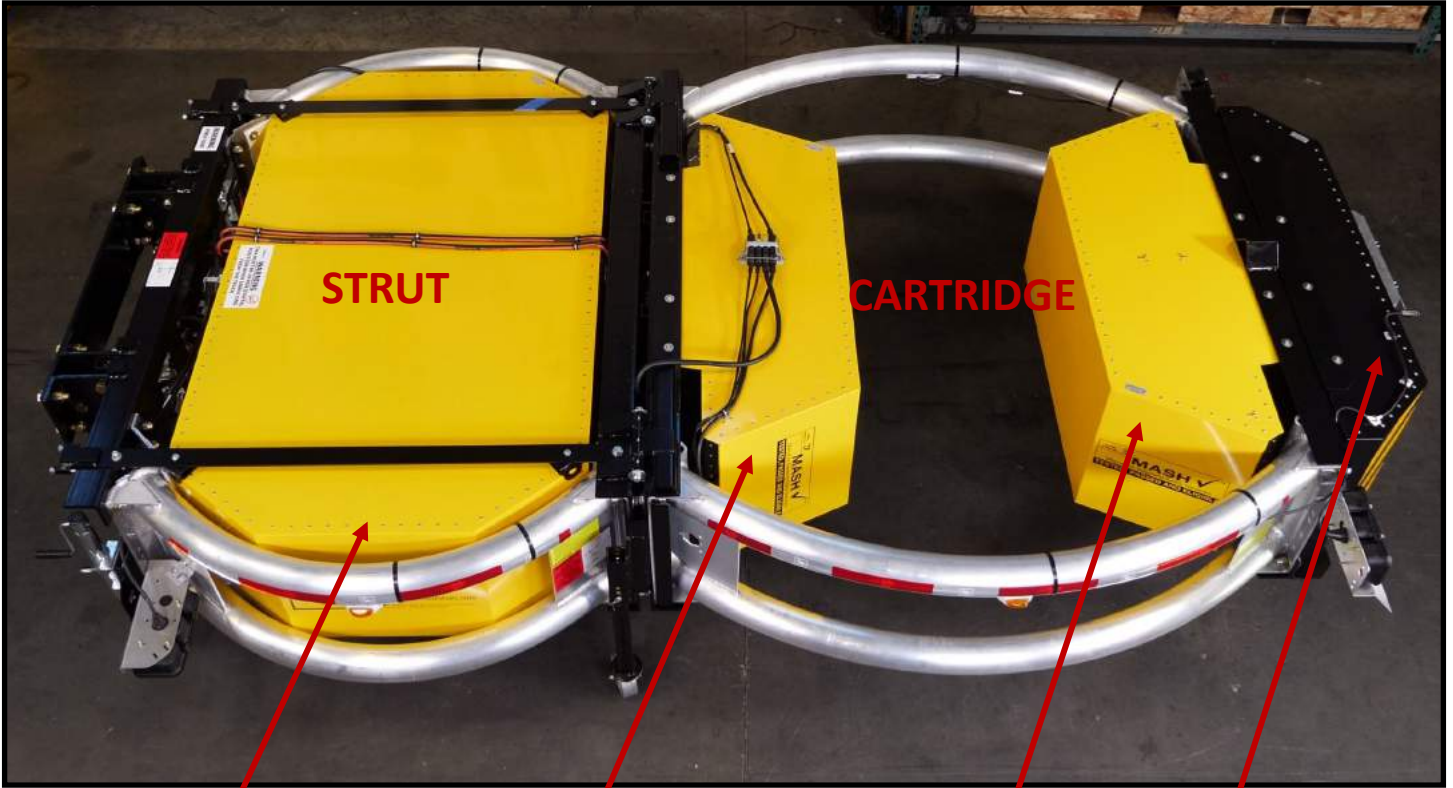

Module D

Module C

Module C

Module A

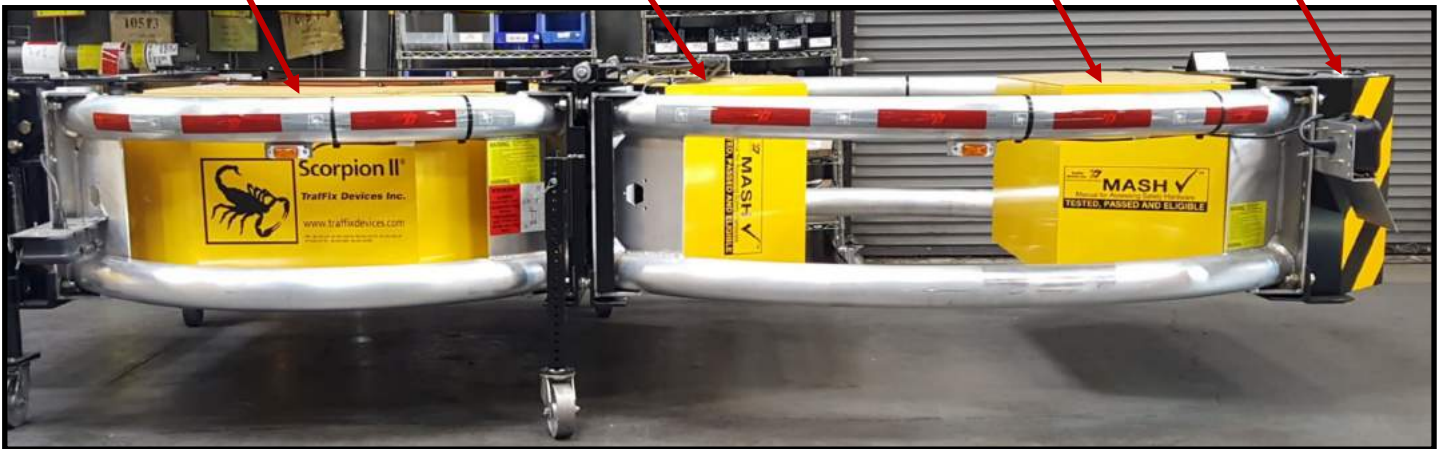

# Hydraulic Pump Assembly

1. Fill the reservoir on the hydraulic pump with three gallons of Automatic Transmission Fluid (ATF) and attach the electrical wires (minimum gauge size of #1 battery cable for both the positive and negative hydraulic motor connections) to the motor cables. Push the “up” button on the yellow controller to raise the TMA to its stored position.
2. Fill the reservoir a second time with two more quarts. Cycle the system two times waiting 3 minutes between cycles to remove the air bubbles from the system. Fill the rest of the reservoir with two quarts of hydraulic fluid.
3. Roll the TMA back to the host vehicle and bolt the four hydraulic angle brackets to the backing plate first, before installing the TMA onto the host vehicle. Use full manual torque with a breaker bar and a wrench to fasten the brackets to the backing plate.
4. Finish with the TMA in the deployed position to mount onto the host vehicle. Terminology for the hydraulic pump and the motor are illustrated below:

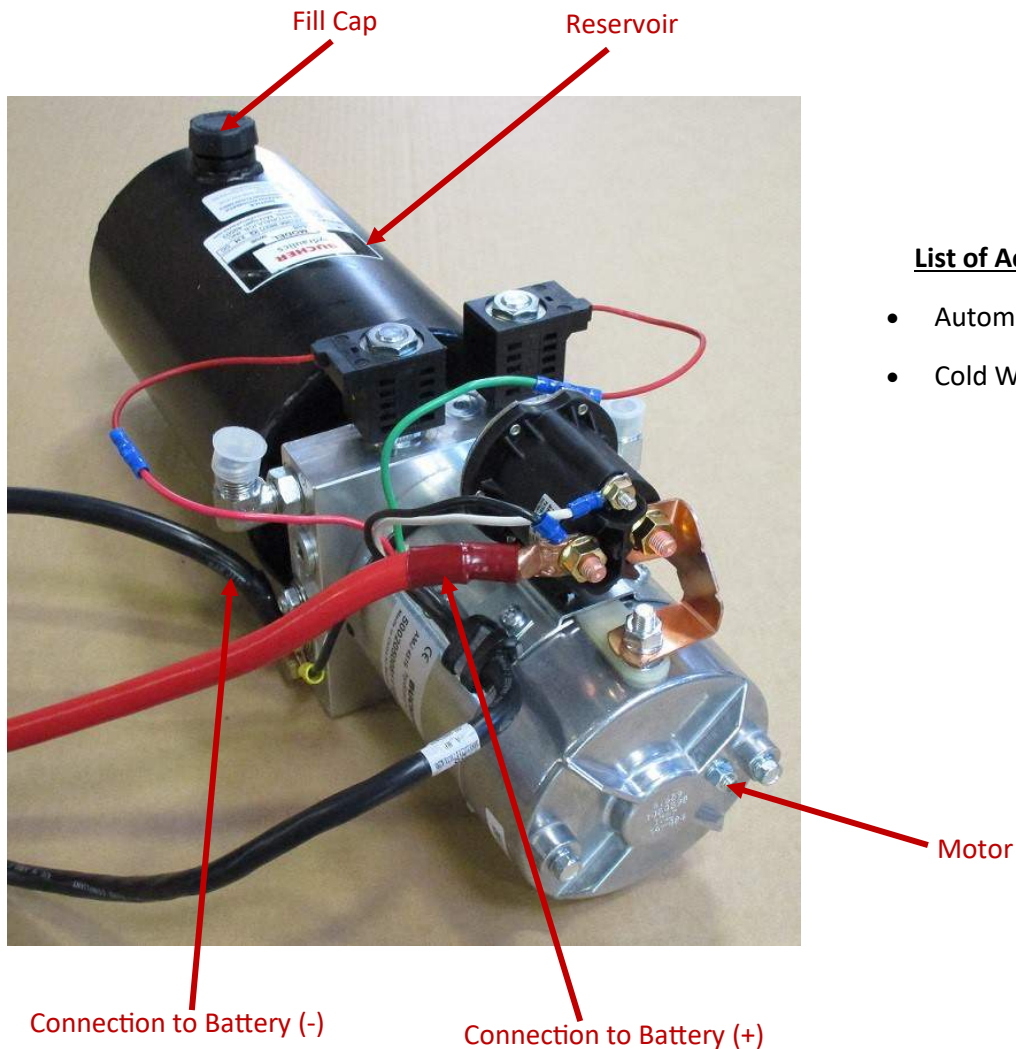

## List of Acceptable Hydraulic Fluids

- Automatic Transmission Fluid (ATF)
- Cold Weather Hydraulic Fluid

# Hydraulic Pump Parts List

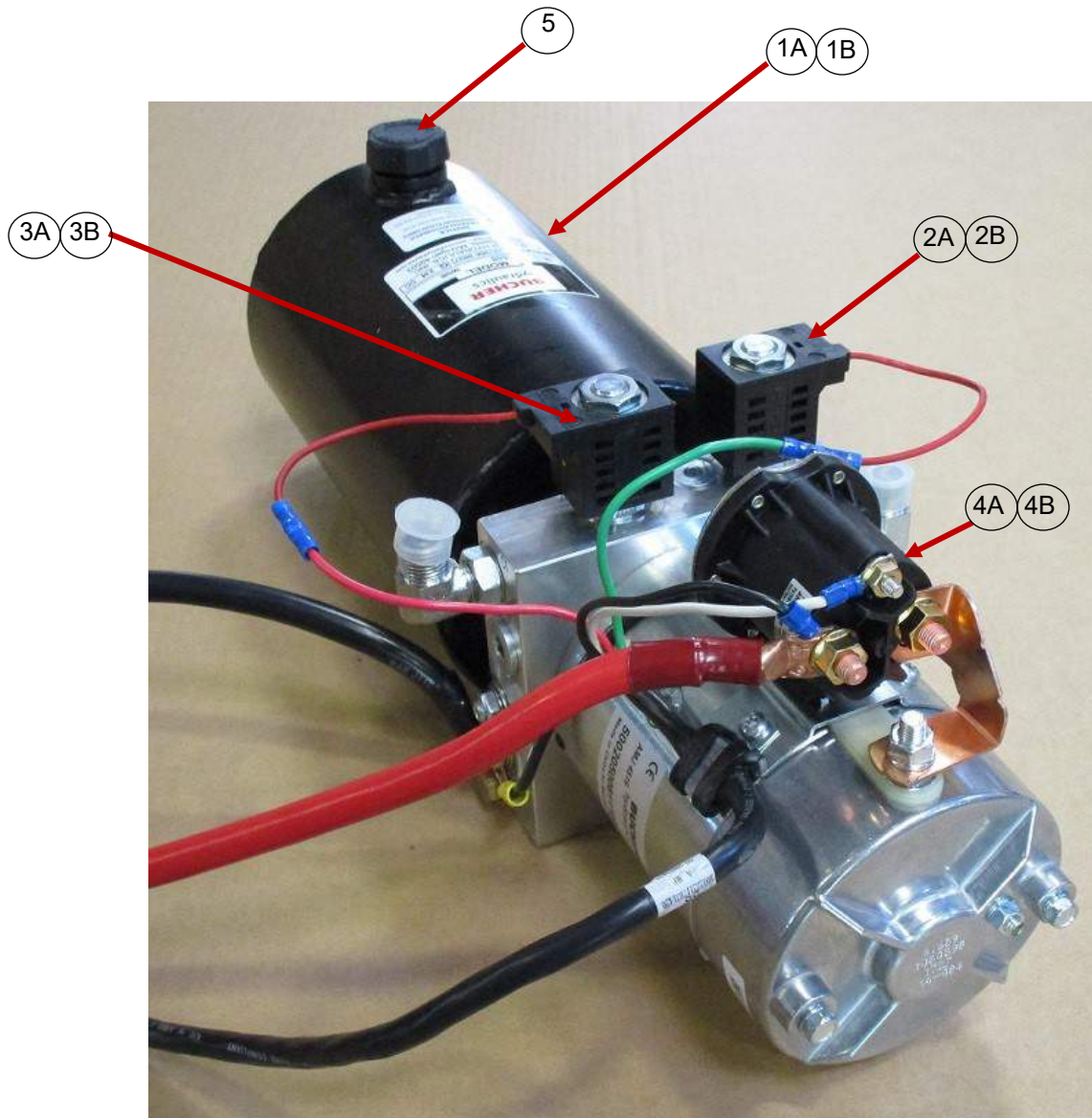

Item #	Part #	Item Description	QTY/TMA
1A	11010	12 Volt Motor w/ Hydraulic Pump - Complete	1
1B	11011	24 Volt Motor w/ Hydraulic Pump - Complete	1
2A	11020-12	Valve w/ 12V Coil, controls "up"	1
2B	11020-24	Valve w/ 24V Coil, controls "up"	1
3A	11021-12	Valve w/ 12V Coil, controls "down"	1
3B	11021-24	Valve w/ 24V Coil, controls "down"	1
4A	11024	12 Volt Solenoid	1
4B	11025	24 Volt Solenoid	1
5	11012NJ-CAP	Filler Cap for TMA Motor	1

# Standard Truck Mounting Installation

**Flat Bed Mount**

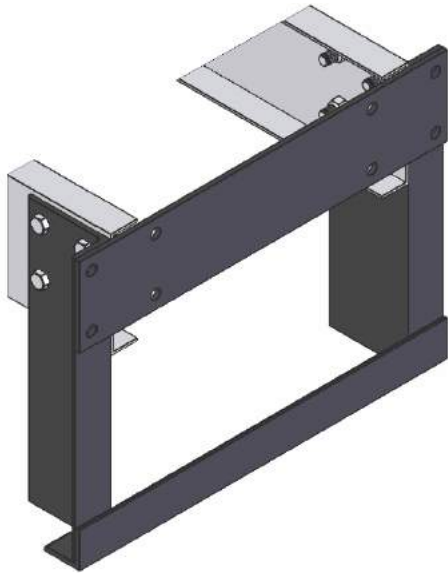

**Dump Truck Mount**

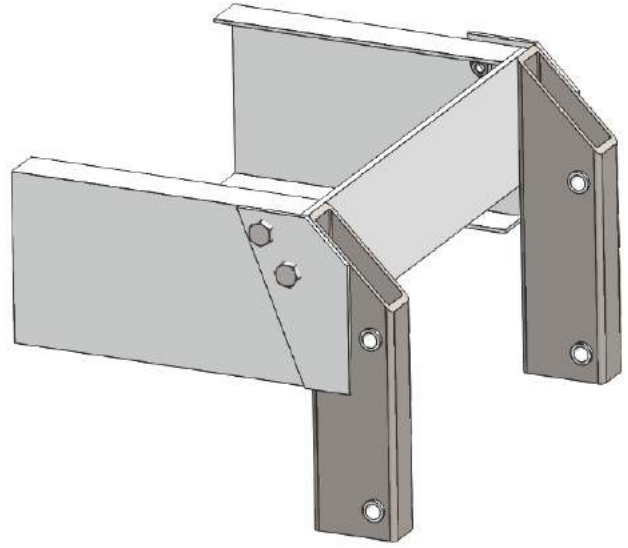

**Fast Trak Swift Connect Mount**

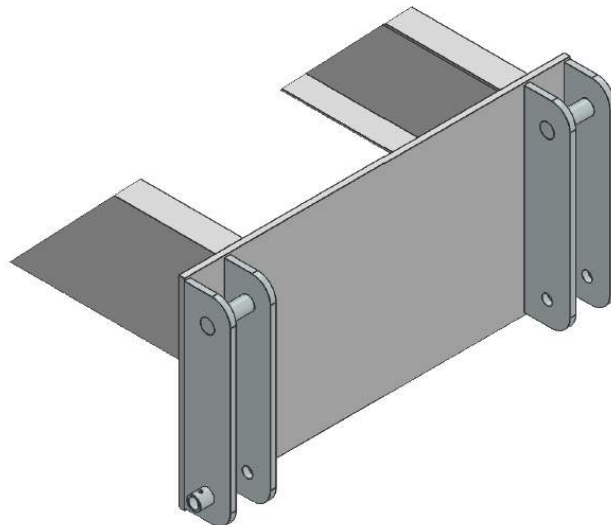

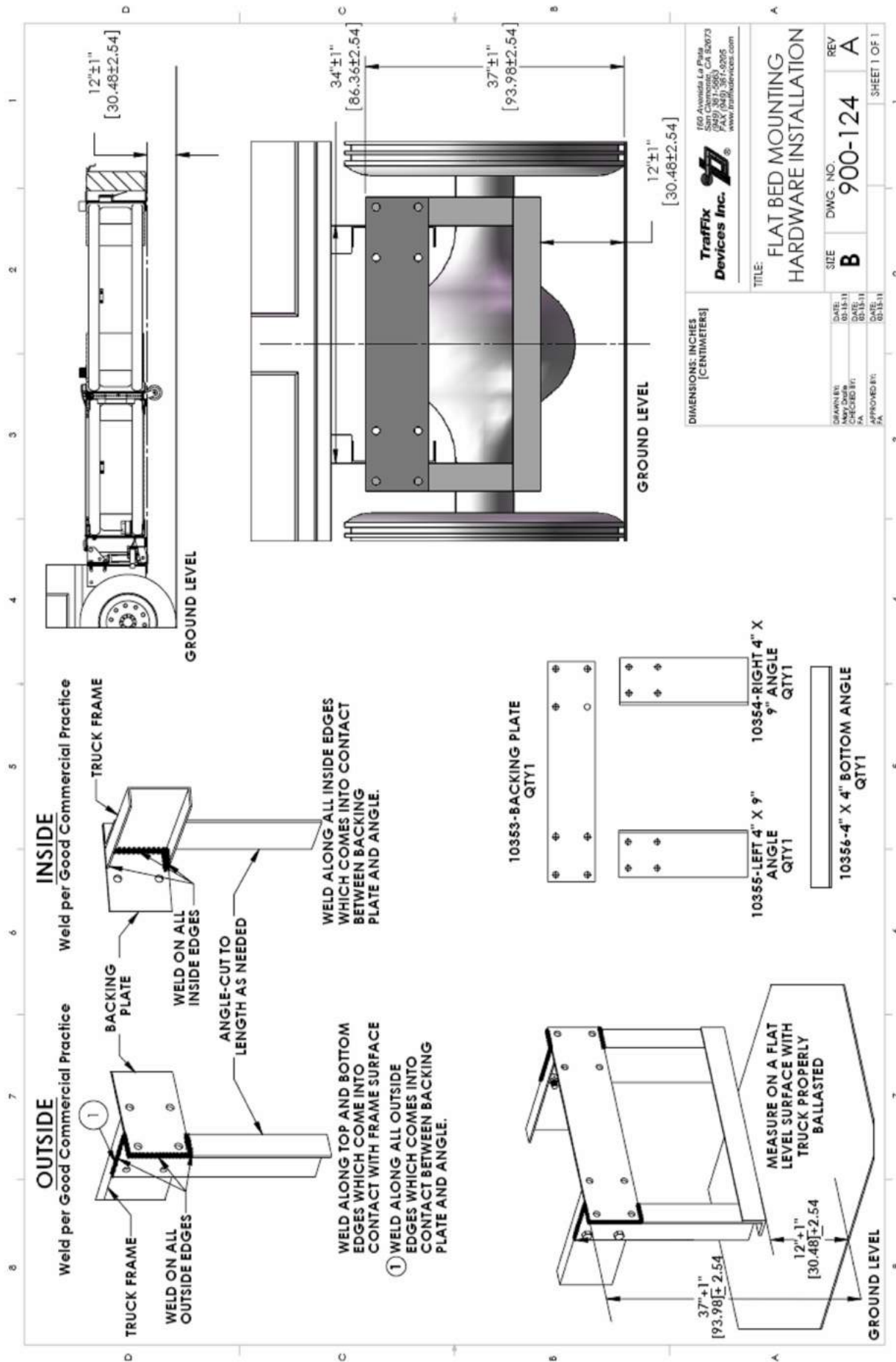

# Standard Flatbed Truck Mounting Installation

## Truck Installation Model C

Before attempting to install the TMA to a host vehicle truck, ensure that the truck meets the following criteria: Truck weight specifications vary from state to state; however, it is recommended that the truck weighs a minimum of 15,000 lbs.

Adding ballast can affect the truck bed height, so it is preferred to **ballast the truck before attaching the TMA**. Check the truck frame to ensure that it is structurally sound and rust-free. Also, check the amount of frame extension in back of the spring brackets – a minimum of 10" is needed. Check that the bed of the truck does not extend beyond the back of the frame more than 4". This is necessary for vertical clearance of the TMA. Check the frame for a cross tie plate connecting one side to the other if the frame extends to the rear more than expected. It is preferred to keep the frame from extending more than 24" from the back of the spring support bracket. Also check the height of the truck side gates. These should be less than 8' 6" from the ground to allow clearance if the double 90° tilt is used.

1. The truck frame consists of two C-channels spaced approximately 34" apart. Grind the inside and outside of the ends of the frame, as shown in this figure (right), in preparation for tack welding process. The frame should be square from side to side. Use a carpenter's square tool or any other square device to verify that the frame is indeed level and straight. Also measure the distance from the frame ends to the back of the spring brackets.

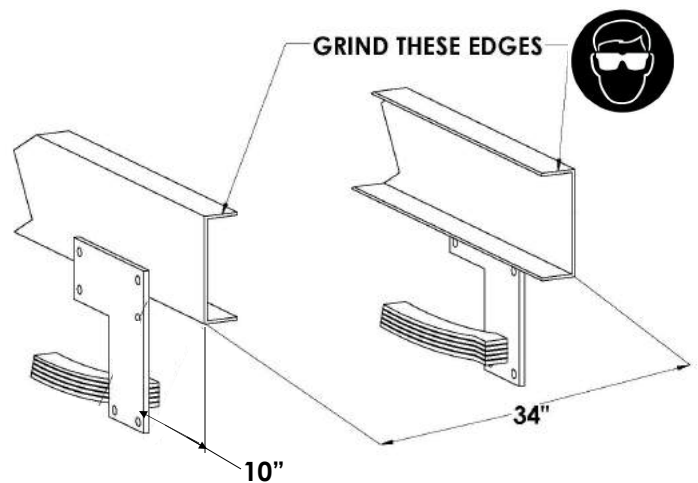

2. Mount the Backing Plate (P/N: 10353) onto the backup of the TMA as shown in this figure (right). Mounting the backing plate onto the TMA will simplify the alignment process when mounting the backing plate onto the truck frame of the host vehicle.

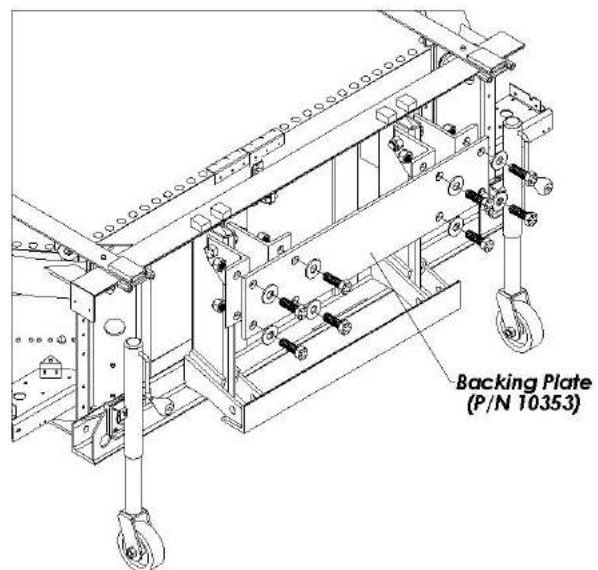

3. With the assembled TMA in the deployed position, deploy and adjust all four jacks on a flat-leveled surface (shown in the figure below) to a height that measures approximately 14 1/2" - 15" from the underside of the TMA to the flat surface. This height is to account for the settling of about 2" that the truck will experience after the TMA is mounted onto the frame when the jacks are raised in their stored position. It is essential to measure and verify the recommended height of 14 1/2"-15" on both sides of each diaphragm. The figure below also illustrates the locations of where that specified height should be measured.

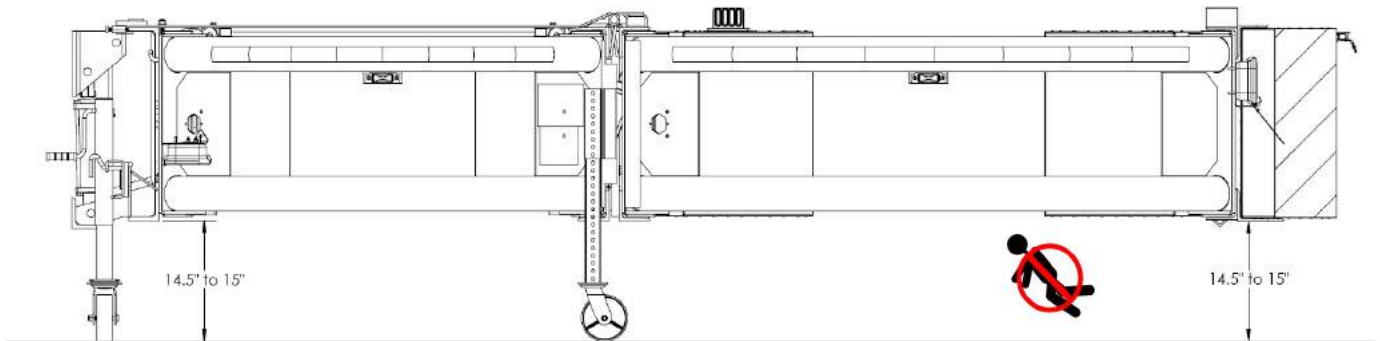

4. With the jacks deployed, roll the deployed TMA to the rear of the host vehicle and align the TMA centerline with the vehicle, as shown in the following figure. The backing plate that is bolted onto the TMA (See step 2) should be flush with the ends of the truck frame.

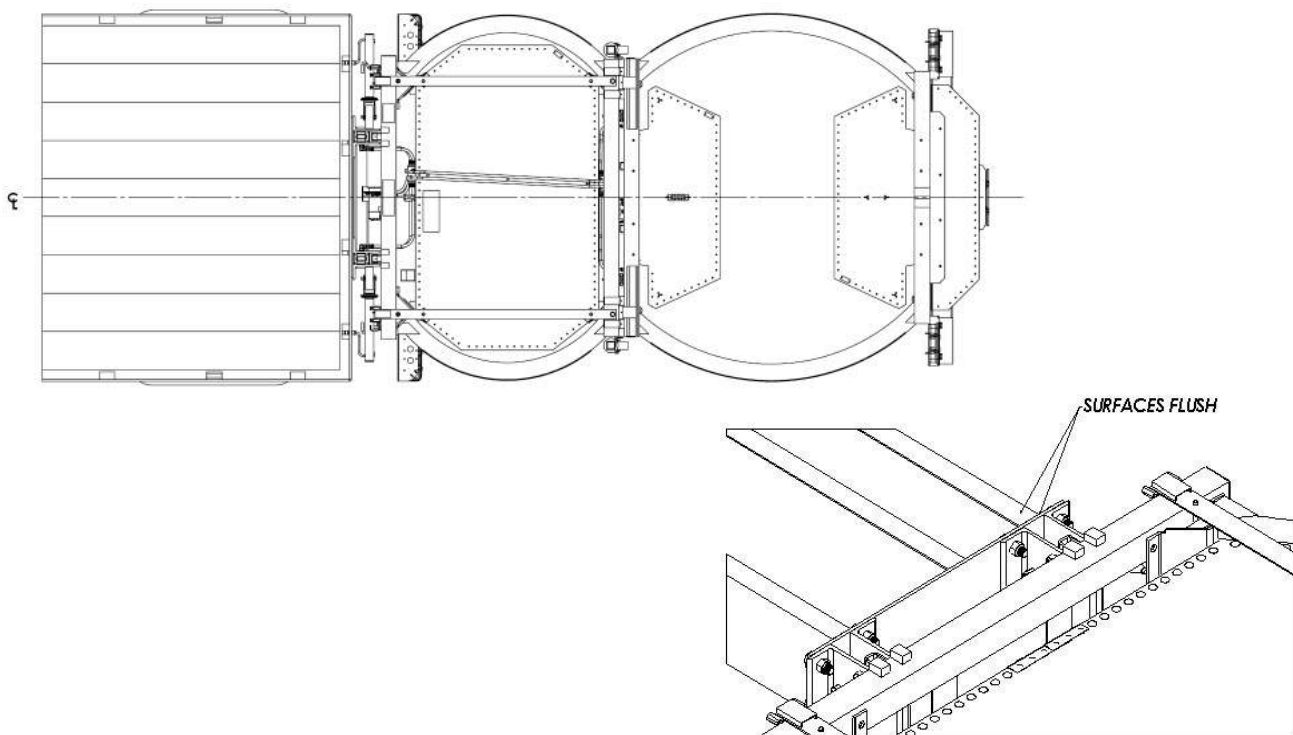

5. After proper confirmation of the backing plate being level and 90° to the horizontal surface, deploy the drops jacks and unbolt the TMA from the backing plate that is already tacked onto the host vehicle. Fully weld the backing plate on both the inside and outside of the frame rails. Proper welding locations are specified in the figure below:

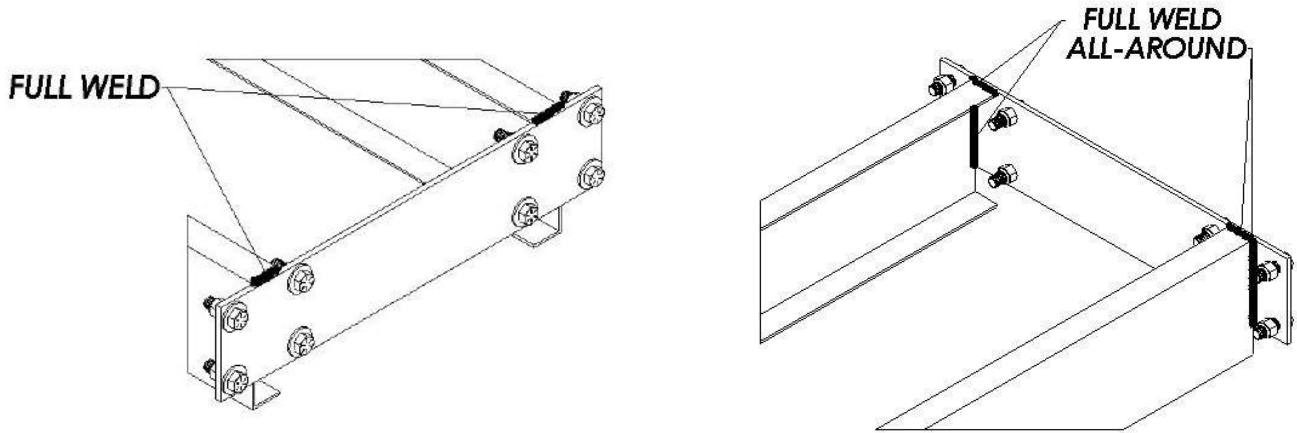

6. Position the 9" x 4" vertical angles with C-clamps on to the side of the frame as shown in first figure (bottom left). Notice there is a left and right side vertical angle and the flanges should be positioned toward the rear of the truck. Four holes are located in the angle for bolting to the frame (refer to middle figure). **Center the holes vertically on the frame** and drill/burn 4 holes in the frame on both sides. Also, drill/burn 2 holes on the angle to align with the outermost holes of the backing plate as shown in the middle figure as well. Bolt the vertical angles onto the frame with the 1" bolts as shown in the last figure (bottom right).

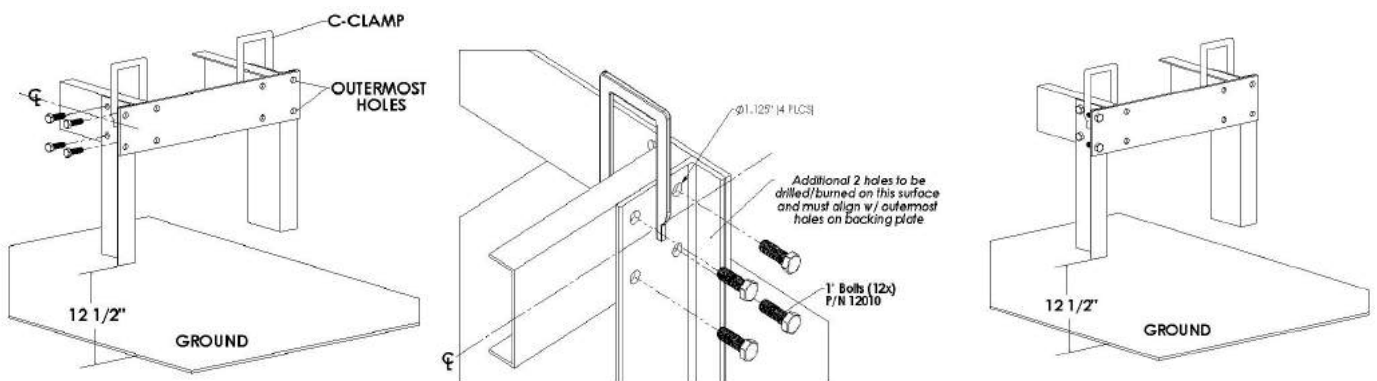



7. Weld the angles in place at the rear of the angle. Refer to the figure below for proper welding locations.

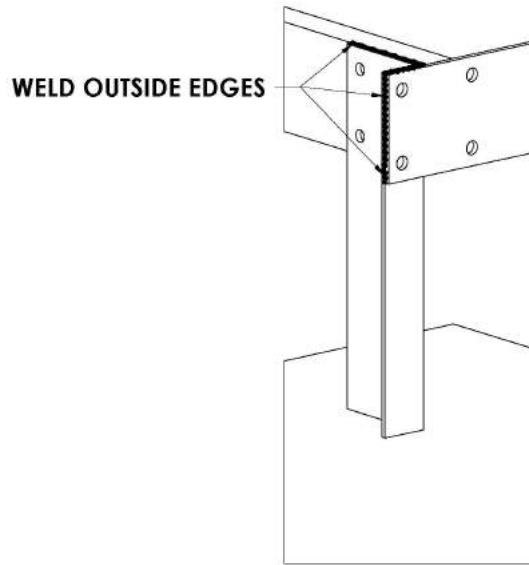

**LEFT FRONT OF BACKING PLATE  
(DRIVER SIDE)**

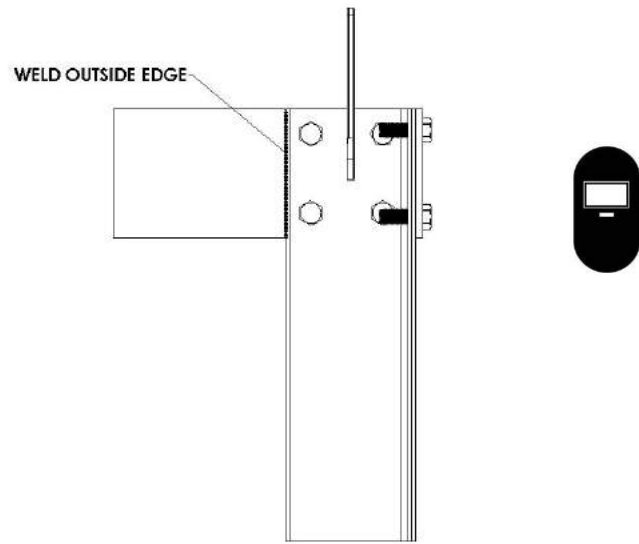

**LEFT FRONT OF BACKING PLATE  
(SIDE VIEW)**

8. Install the lower bottom angle (P/N: 10356) and fully weld the angle in place. Refer to the following figure for proper welding locations.

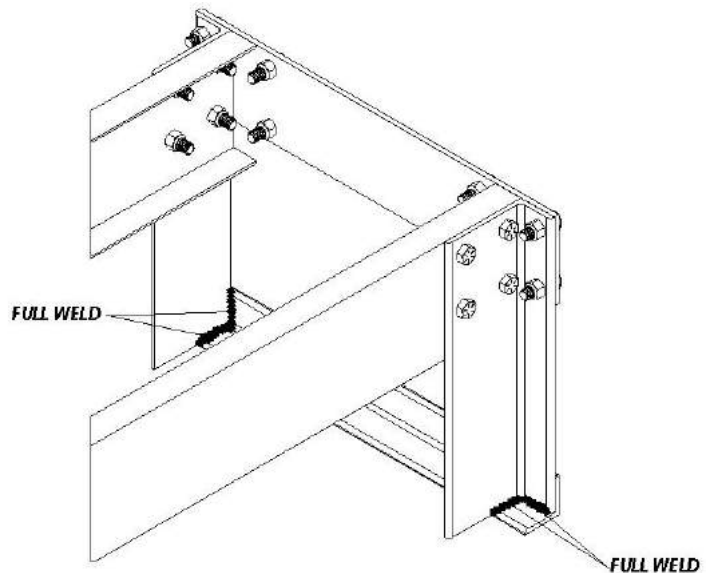
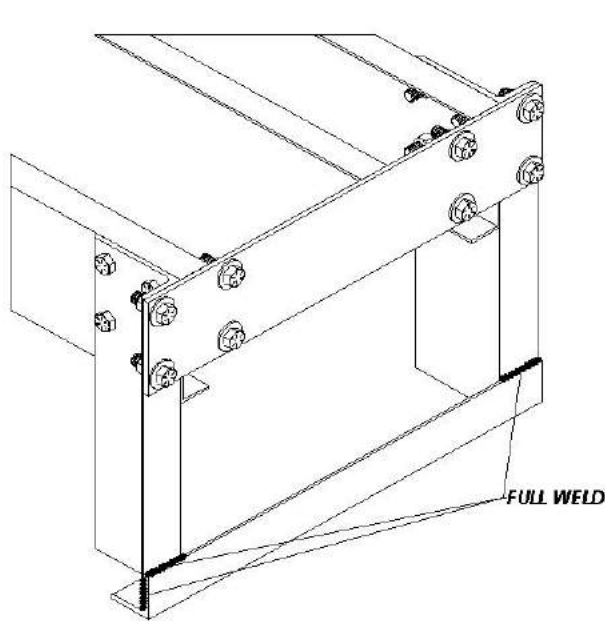

9. Proceed to the Section titled "Support Installation" and follow the Installation that matches the type of Supports you ordered.

# Dump Truck Mounting Installation

## Installation of Extension Frame

Before attempting to install the TMA to a host vehicle truck, ensure that the truck meets the following criteria: Truck weight specifications vary from state to state; however, it is recommended that the truck weighs a minimum of 15,000 lbs.

Adding ballast can affect the truck bed height, so it is recommended to ***ballast the truck before attaching the TMA.*** Check the truck frame to ensure it is structurally sound and rust-free. Also, check the amount of frame extension in back of the spring brackets – a minimum of 4" is needed. Verify that the bed of the truck does not extend beyond the back of the frame more than 15". This is necessary for vertical clearance of the TMA when in the stored position. Ensure that the truck side gates are measured at a maximum height of 8' 6" from the ground to allow clearance if a Model C TMA is being used and is in the stored position.

1. The truck frame consists of two C-channels spaced approximately 34" apart. Dump trucks often have a ½" thick plate welded across the back of the frame. A plate must first be installed before the extension frame can be mounted if a plate is not present. Grind the inside and outside edges of the frame, as shown in this figure (right), to prepare for a weld. Verify that the frame is square from side to side, using a carpenter's square tool or any other square device. Also measure the distance from the frame ends to the back of the spring brackets.

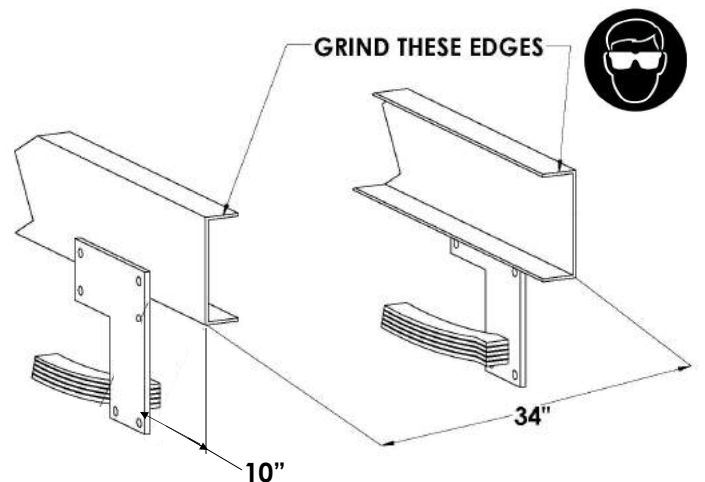

2. A backing plate (33" x 10") should be centered on the back of the truck frame. Note where the frame will be welded to the plate and grind the plate in this location. Tack weld the rear plate into position and make sure that the rear plate is positioned vertically at 90° to horizontal. Continue by welding the inside of the frame end to the plate.

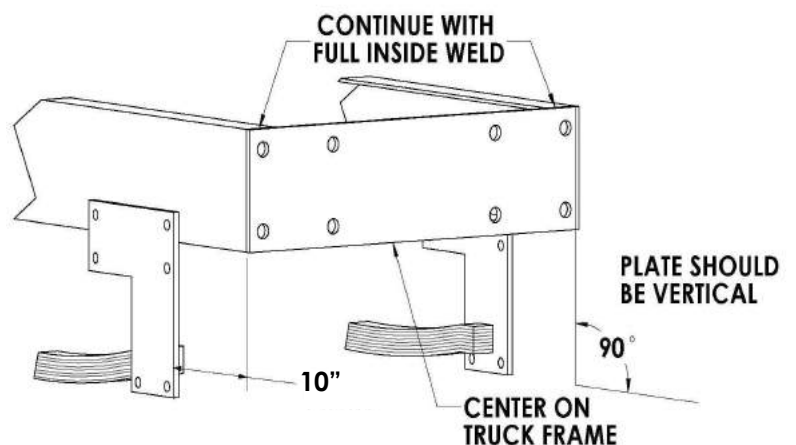

3. The extension frame comes with the right and left vertical tubes bolted in place in the right and left frame sections as shown in the first figure below. For ease of attachment to the truck, mount the extension frame to the TMA, as seen in the below second figure, and roll the TMA with the extension frame to the back of the truck,. Make sure the TMA is at 14 ½" - 15" in height, measured from the underside of the TMA to the ground. This height is to account for the settling of about 2" that the truck will experience after the TMA is mounted onto the frame when the jacks are raised in their stored position.

**SPLICE PLATES  
SHIPPED SEPARATELY**

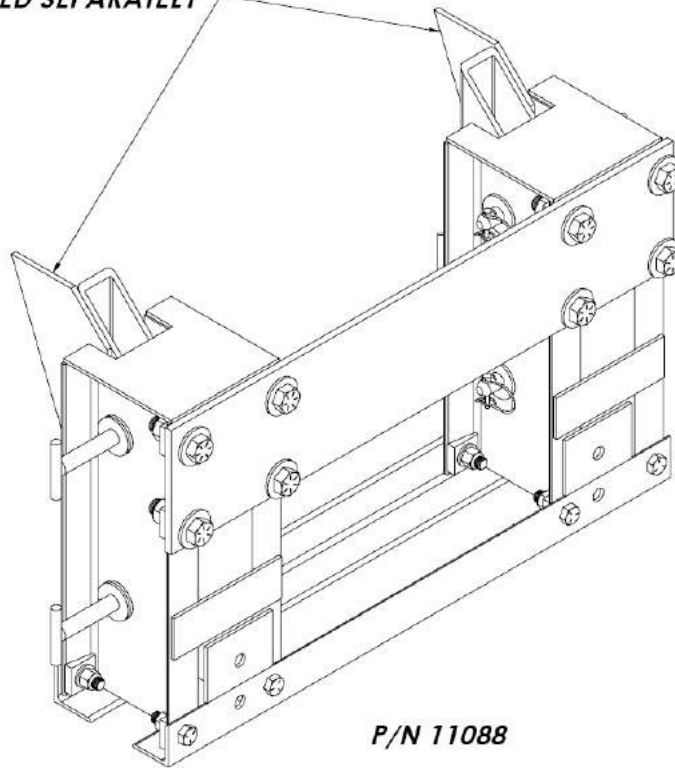

**P/N 11088**

**EXTENSION FRAME SHOWN  
WITHOUT SPLICE PLATES**

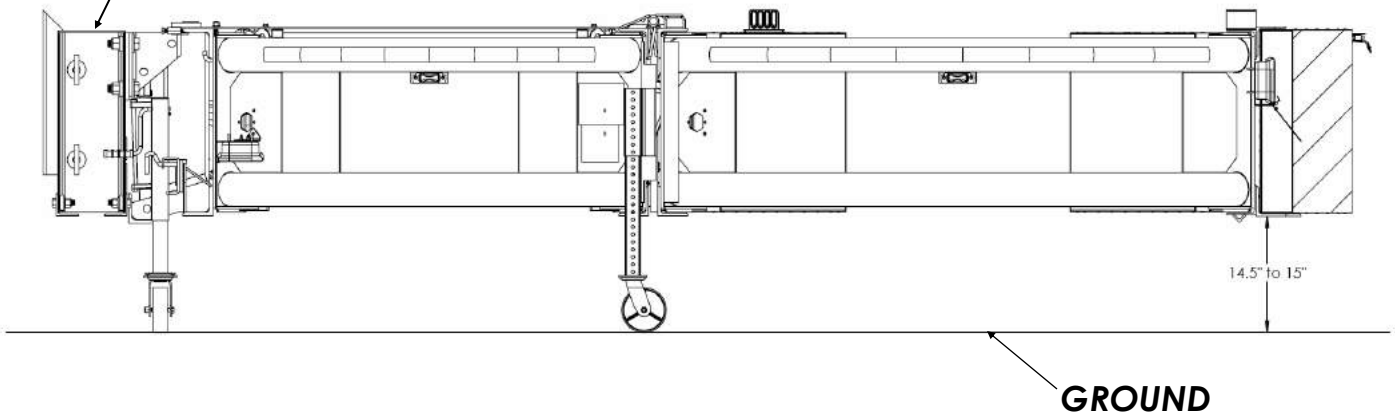

14.5 to 15"

**GROUND**

4. Once the TMA is rolled towards the back of the host vehicle, tack weld the tubes in place at the outermost and innermost four corners where the tubes touch the frame. This image below illustrates ideal tack welding locations to hold the tubes in place.

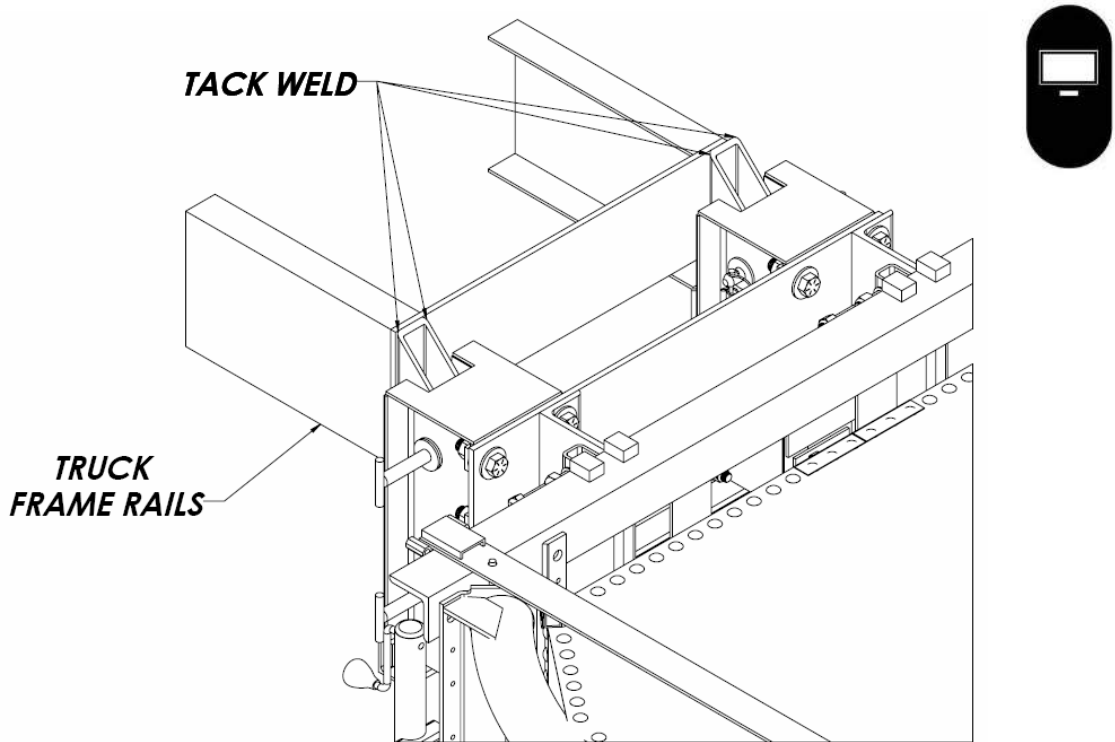

5. Remove the four 1" bolts from the vertical tubes and roll the TMA rearward to pull the extension frame free from the vertical tubes. Fully weld the tubes in place on all four sides where the tubes touch the frame and the back plate. Refer to following figure for details.

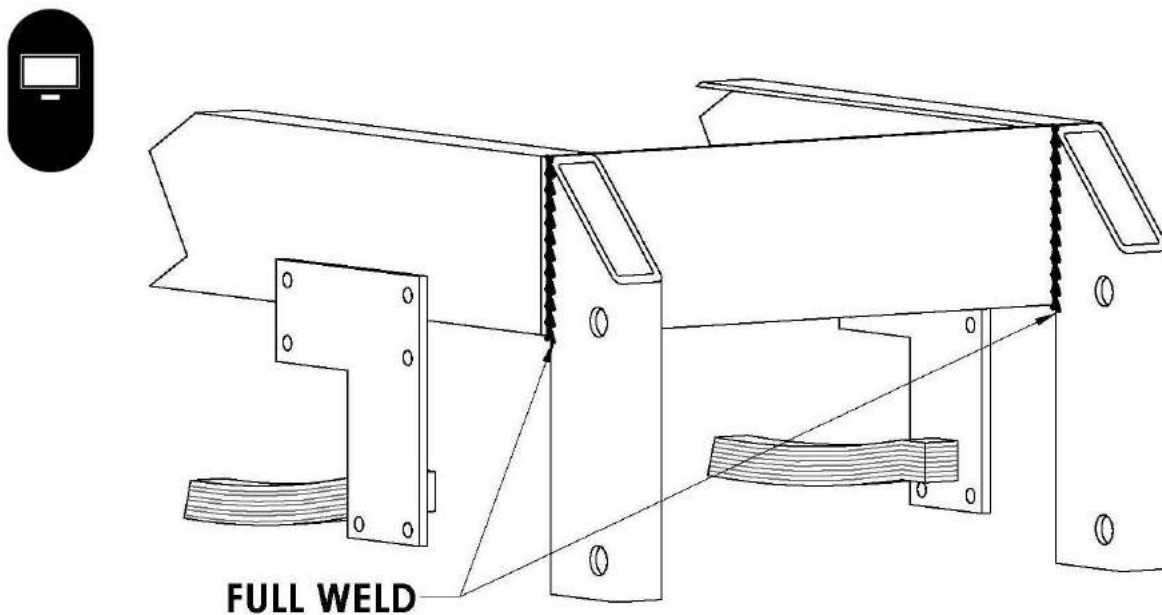

6. Position the splice plates, as shown here in this figure below, against the sides of the frame and the vertical tubes. Mark on the plate the position of two holes for  $\frac{3}{4}$ " bolts. Drill these holes in the plates and the frame. Weld the edge of the plate to the vertical tube. The truck frame weld areas should be spray painted to prevent rust.

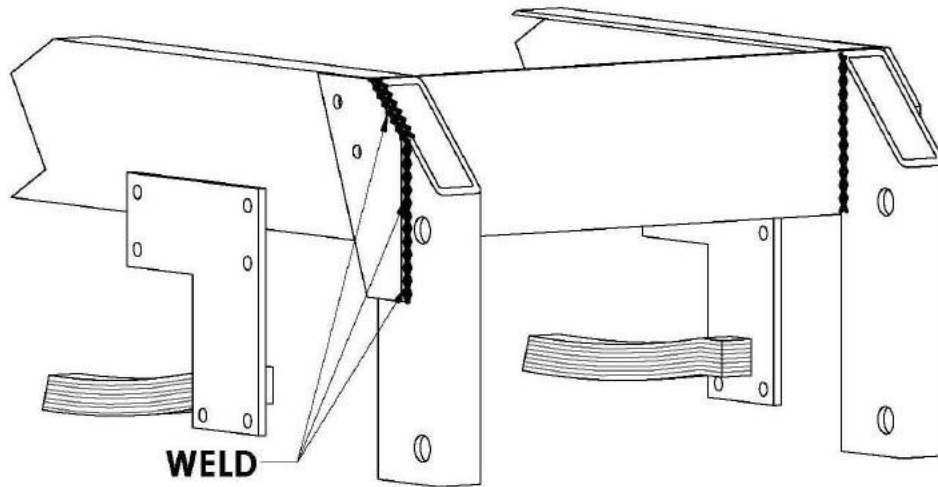

7. After the splice plates have been welded on the tubes, Install the four  $\frac{3}{4}$ " bolts in the designated holes that were drilled into the plates to reinforce the splice plates as well as the tubes..

8. To reattach the TMA to the truck, either use the 1" bolts supplied or use the T-pins, if the T-pins were purchased as an option.

9. Proceed to the Section titled "Support Installation" and follow the Installation procedures that match the type of Supports that were ordered.

# Installing the Fast-Trak SwiftConnect™ for the Scorpion Truck Mounted Attenuator (TMA)

(Follow the Directions for the Configuration received)

## Configuration 1

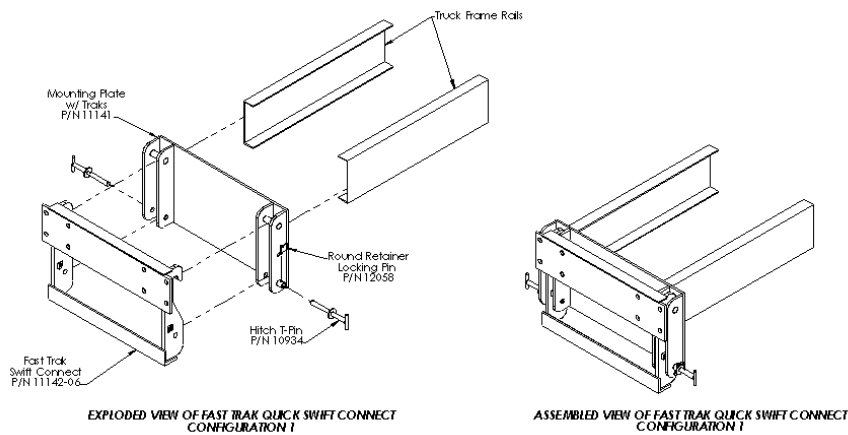

## Configuration 2

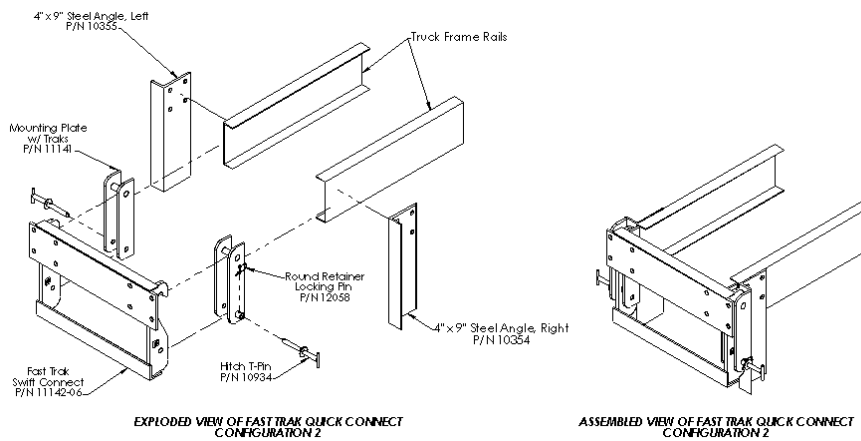

## Configuration 3

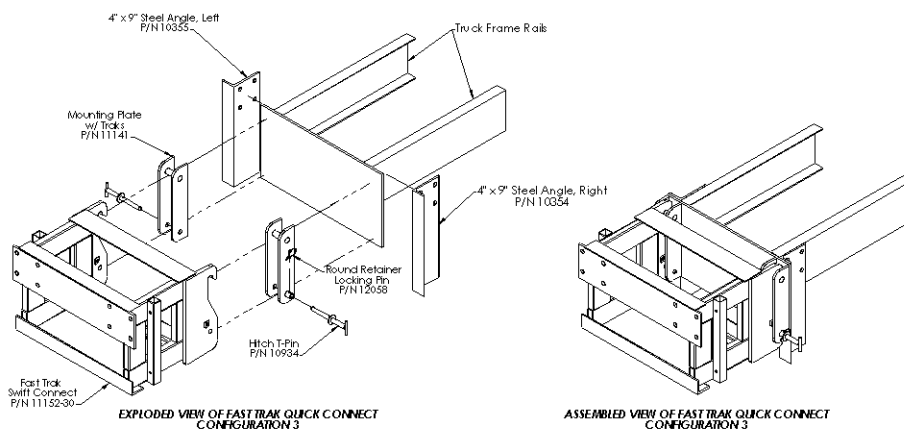

# Fast-Trak SwiftConnect™ Configuration 1

(Configuration 1 is for trucks where the back end of the truck has no plate and only the truck frame rails are exposed.)

PN: 11140-06 used for illustration, other lengths are installed in the same way.

Adding ballast can affect the truck bed height, so it is advisable to ballast the truck before attaching the TMA. Check the truck frame to make sure that it is structurally sound and not rusted. Also check the amount of frame extension in back of the spring brackets – a minimum of 10” is needed. Check that the bed of the truck does not extend beyond the back of the frame more than 4” (see Fig. 3). This is necessary for vertical clearance of the TMA. Check the frame for a cross tie plate connecting one side to the other if the frame extends to the rear more than a few feet. It is preferred to keep the frame from extending more than 24” from the back of the spring support bracket. Also check the height of the truck side gates. These should be less than 8’ 6” from the ground to allow clearance if the double 90° tilt is used.

Part number 11141 truck mount comes with a plate to be welded to the truck frame rails. Before fully welding part number 11141 truck mount to the frame rails, tack in the part to ensure proper alignment and height recommendations from the ground. Refer to the Scorpion TMA Dump Truck Mount recommendations. Once fully welded, use Figure 1 below for installation and assembly for all of the components for Configuration 1.

1. The truck frame should be two c-channels spaced 34” apart. Start by grinding the inside and outside of the end of the frame to prepare for a weld. Make sure that the frame is square from side to side by measuring the same distance from the frame ends to the back of the spring shackles.

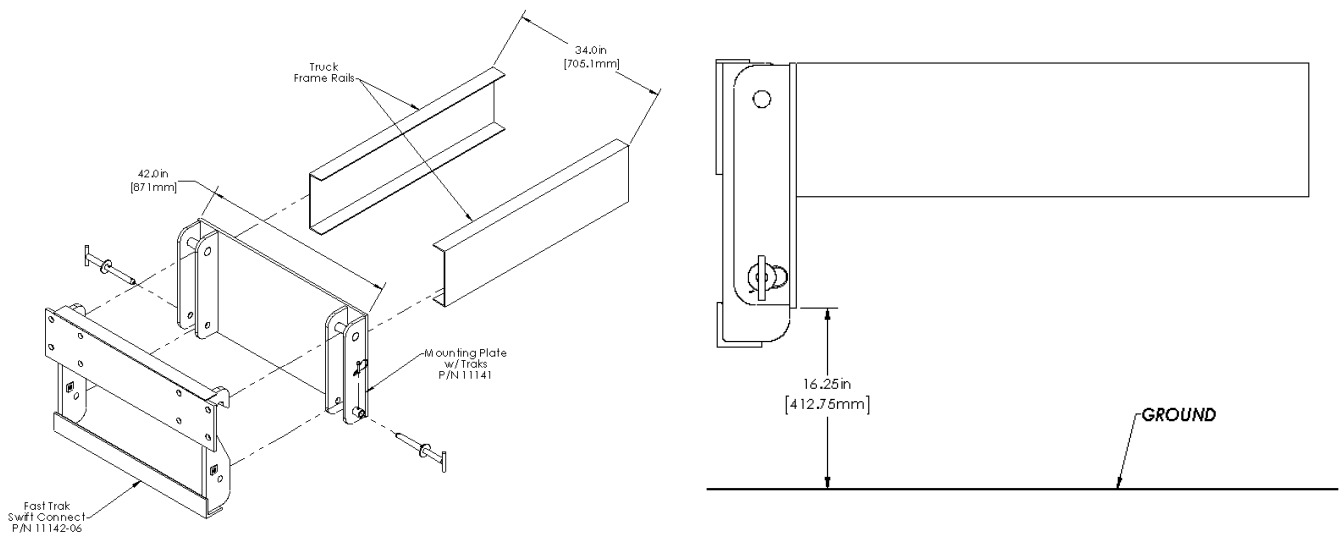

Figure 1: Exploded and assembled view of Configuration 1.

2. The rear plate (42” x 22”) (shipped with the strut) will be centered on the back of the truck frame and the bottom of the Truck Mount Frame will be 16-1/4” above the ground. The truck will settle about 1/2” after installation of the TMA and this is accounted for. REMEMBER THAT THE TRUCK MUST BE BALLASTED BEFORE WELDING THE REAR PLATE ON THE TRUCK FRAME. Note where the frame will be welded to the plate and grind the paint off the plate in this location.

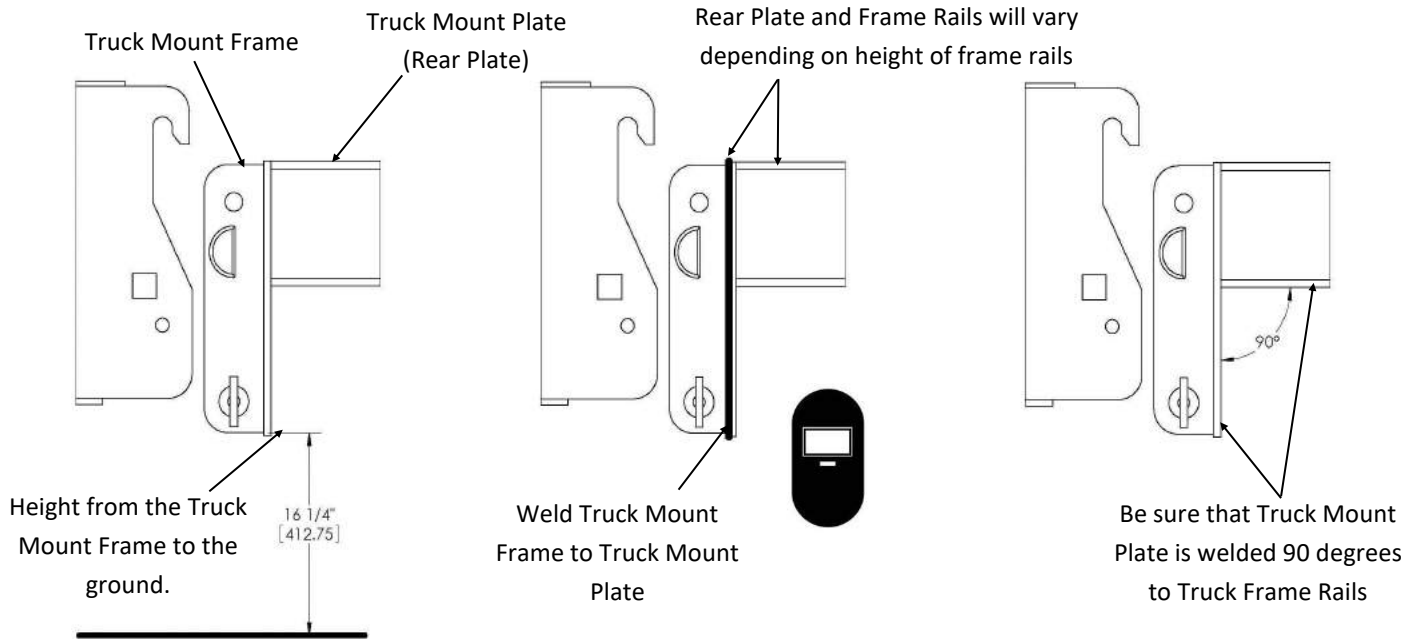

Figure 2: General information on the Fast-Trak/SwiftConnect.

3. Tack weld the rear plate into position and make sure that the Truck Mount Frame is at 16-1/4" above ground, is level across the top, and positioned vertically at 90° to horizontal. Continue by welding the inside and outside frame end to the plate. Note: If the rear plate cannot be positioned on the truck frame rails to allow the truck mount frame be at 16-1/4" above ground, then cut the welds between the Truck Mount Frame and the Rear Plate. Position and weld the Rear Plate first as mentioned above. Then position and weld the Truck Mount Frame to the Rear Plate as mentioned above.

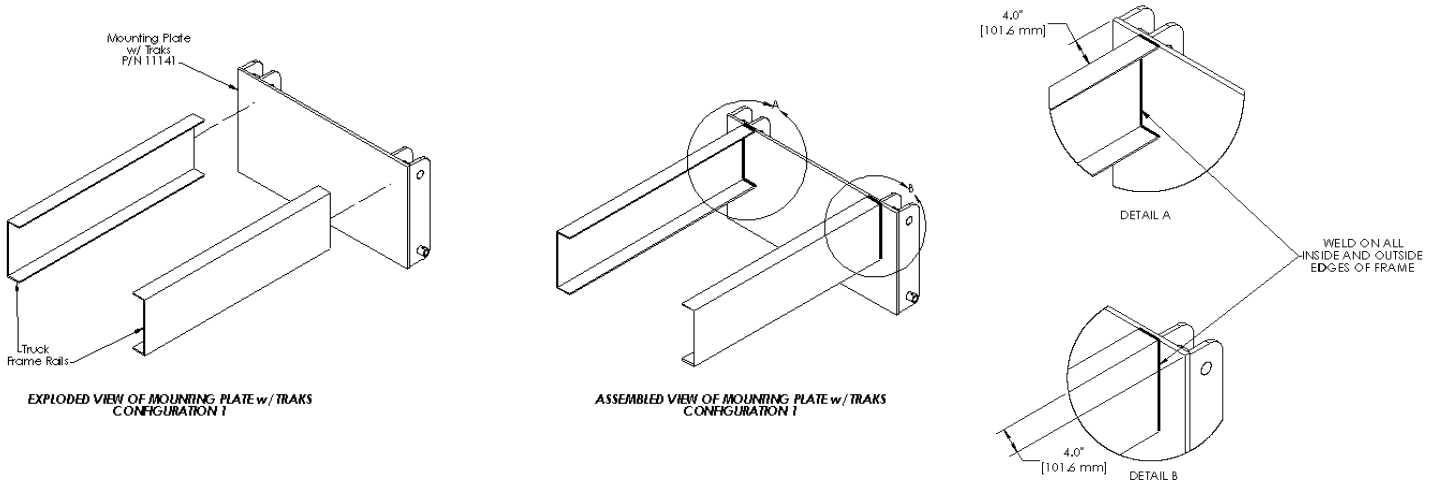

Figure 3: General information on the Fast-Trak/SwiftConnect.

Table 1: Configuration 1 components.

Configuration 1 (PN 11140-06) Components		
Part Number	Description	Quantity
11142-06	TMA Side Mount (FTSC 6")	1
11141	Mounting Plate w/ Traks (Truck Side Mount)	1
10934-FTSC	Hitch T-Pin	2
12058	Round Retainer Locking Pin	2



## Fast-Trak SwiftConnect™ Configuration 2

Plate already welded on truck

PN: 11145-06 used for illustration, other lengths are installed in the same way.

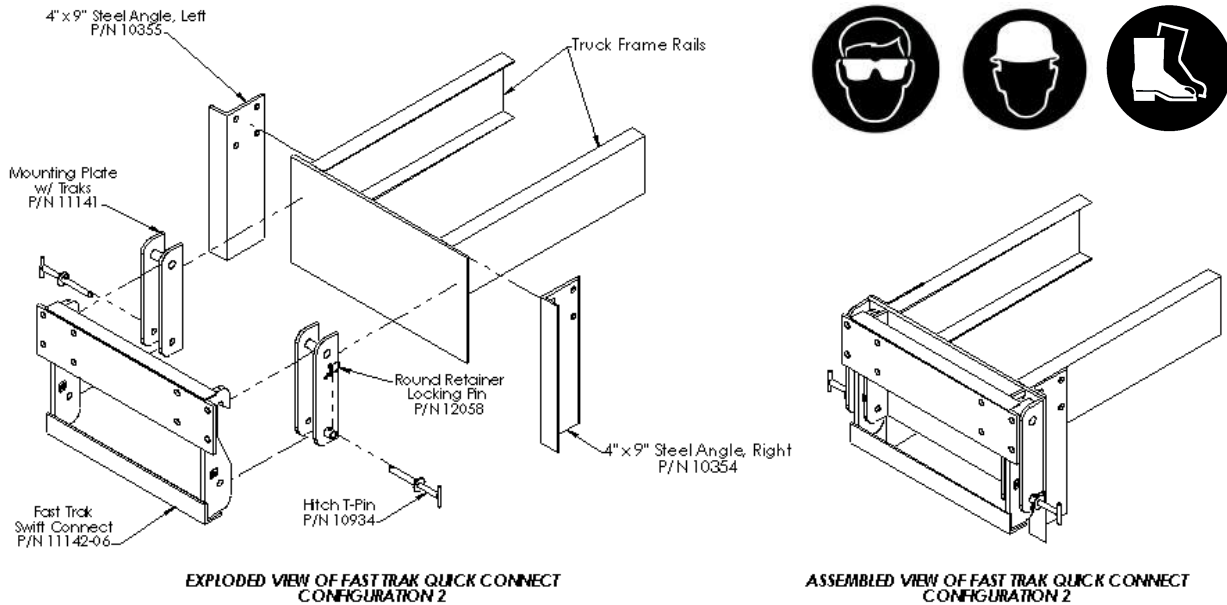

Figure 4: Exploded and assembled view of Configuration 2.

Configuration 2 is for trucks where the back end of the truck has a sturdy plate already welded to the truck frame rails. Before fully welding part number 11146 truck mount to the frame rails, tack in the part to ensure proper alignment and height recommendations from the ground. Refer to the Scorpion TMA Dump Truck Mount for recommendations. Once fully welded, use Figure 4 above for installation and assembly for all of the components for configuration 2. Additionally, refer to Step 3 of Configuration 1 for further instructions on positioning and welding PN 11146 to the Rear Plate.

Configuration 2 (PN 11145-06) Components		
Part Number	Description	Quantity
11142-06	TMA Side Mount (FTSC 6")	1
11146	FTSC Side Traks (Truck Side Mount)	1
10354	4" x 9" Steel Angle, Right	1
10355	4" x 9" Steel Angle, Left	1
10934-FTSC	Hitch T-Pin	2
12058	Round Retainer Locking Pin	2

## Fast-Trak SwiftConnect™ Configuration 3

Side mounts for truck side

PN: 11155-30 used for illustration, other lengths are installed in the same way.

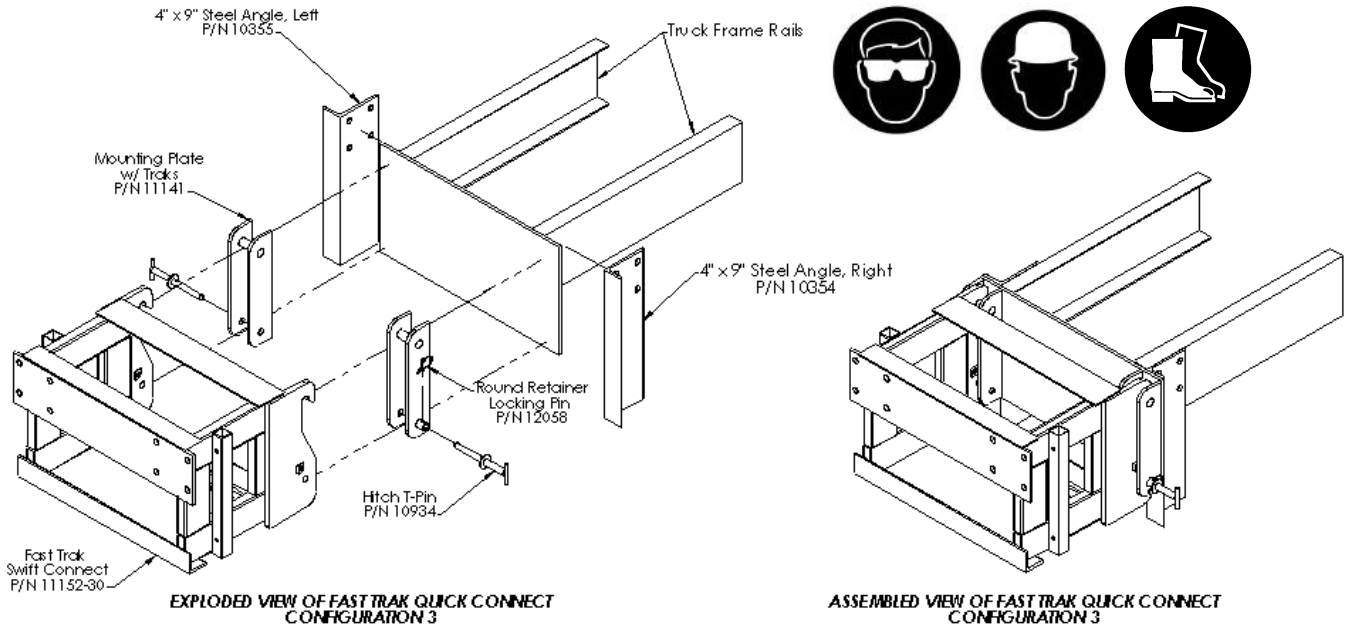

Figure 5: Exploded and assembled view of Configuration 3.

Configuration 3 is used for applications where an extension is required such as a bed overhang. Before fully welding the truck mount to the frame rails, tack in the part to ensure proper alignment and height recommendations from the ground. Refer to the Scorpion TMA Dump Truck Mount for recommendations. Once fully welded, use Figure 5 above for installation and assembly for all of the components for Configuration 3.

Table 4: Configuration 3 components.

Configuration 3 (PN 11155-30) Components		
Part Number	Description	Quantity
11152-30	TMA Side Mount (FTSC 30")	1
11141	Mounting Plate w/ Traks (Truck Side Mount)	1
10354	4" x 9" Steel Angle, Right	1
10355	4" x 9" Steel Angle, Left	1
10934-FTSC	Hitch T-Pin	2
12058	Round Retainer Locking Pin	2

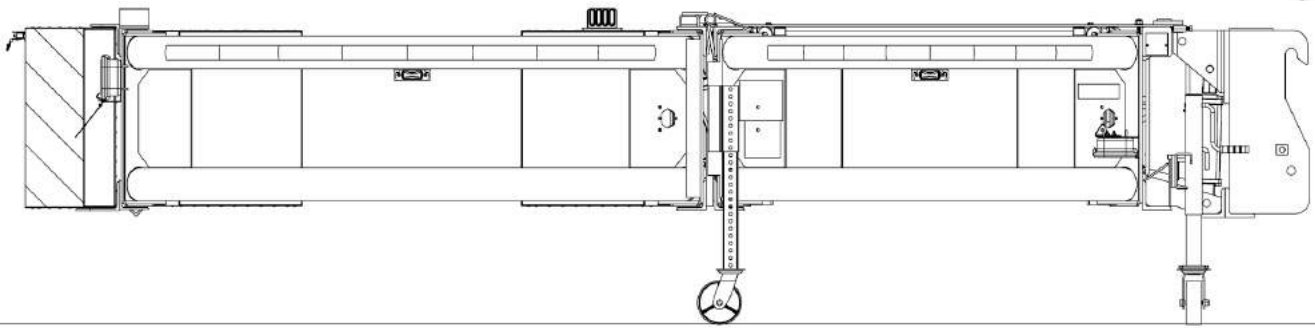
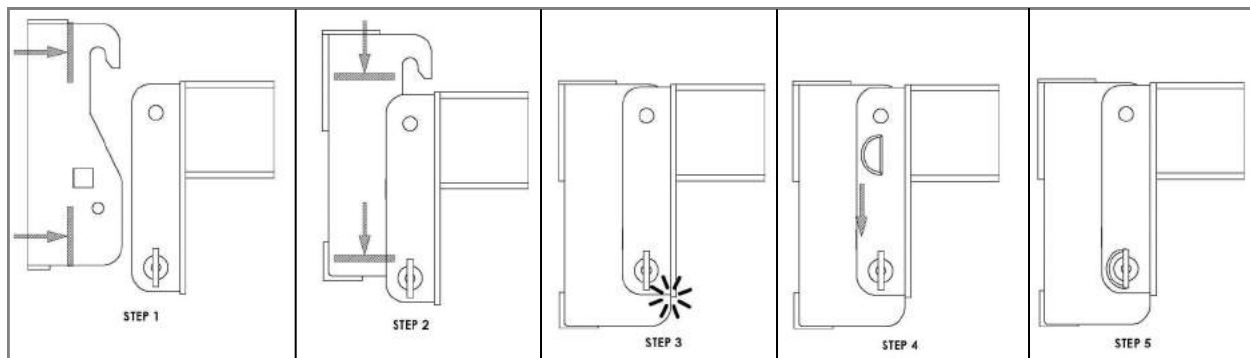

Figure 6: Display of Fast-Trak Swift Connect mounted onto TMA

This is what the TMA should look like when it is not installed onto a Truck, see Figure 6. All Jacks should be deployed and secure prior to installing the TMA onto a Truck. The Truck mounting side of the TMA should be high enough such that the hooks can go over the pins on the Truck-side mount, but the Truck side should be lower than the rear of the TMA by a couple of degrees. This can be achieved by adjusting the Drop Jacks prior to removal of the TMA from the truck to expose one yellow hole below the black Drop Jack Bracket and then use the Swivel Jacks until an appropriate angle and height is achieved.

Figure 7: Step-by-Step Process on how to mount FTSC onto Trucks



Step 1	Step 2	Step 3	Step 4	Step 5
Be sure that the Hook on the TMA side is above the Pin on the Truck Side. Adjust accordingly if necessary. With the securing Pins and Clips removed from the Truck side, push the TMA up to the Truck Mount.	Using the Swivel Jacks, lower the TMA until the hook is fully engaged on the top Pin of the Truck Mount.	Momentarily push the "Up" button on the 2-Button Controller until the bottom of the TMA Side is against the bottom of the Truck Side.	Once the TMA is fully loaded on the Truck Mount top Pin, store away the Swivel Jacks and secure the TMA with the Pins and Clips.	Now that the TMA is fully secured on the Truck, use the controls to lift the TMA high enough to store the Drop Jacks. Once these Jacks are stored, the TMA is ready for the road.

# Support Post Installation



**FLAT BED SIDE SUPPORT**



**FLAT BED CENTER SUPPORT**



**DUMP TRUCK SIDE SUPPORT**

# Flat Bed Side Support Installation



# Flat Bed Side Support Installation

1. Mount the bottom support brackets (P/N 11123) on each side of the flat bed. Mark the position of the holes for the 1/2" bolts and drill these holes in the sides of the bed to fasten the bottom support bracket in to place. The outer lip portion of the bracket should rest on the topside of the bed, as shown in the figure below.

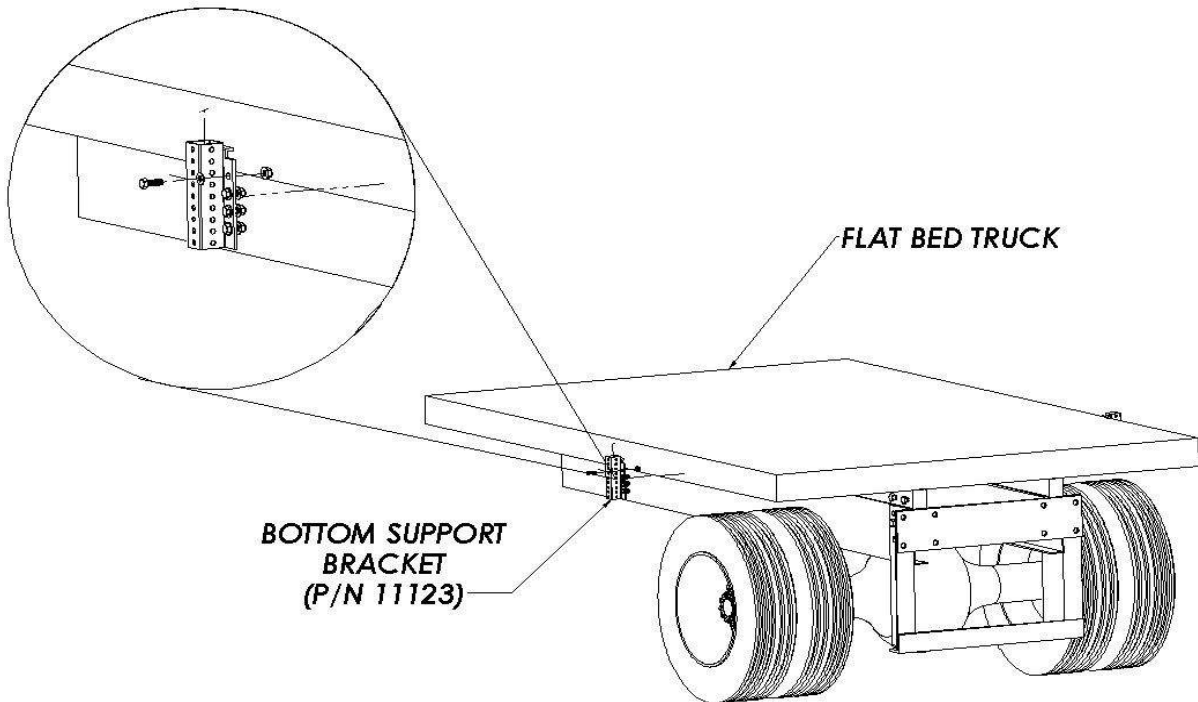

2. Insert the support post into the bottom support bracket. Adjust the post to the appropriate height, which will vary based on the host vehicle, to where the Cartridge tubes will be able to rest on the support post top saddle when the TMA is in the stored position. This figure below illustrates how the support posts can be adjusted upon installation.

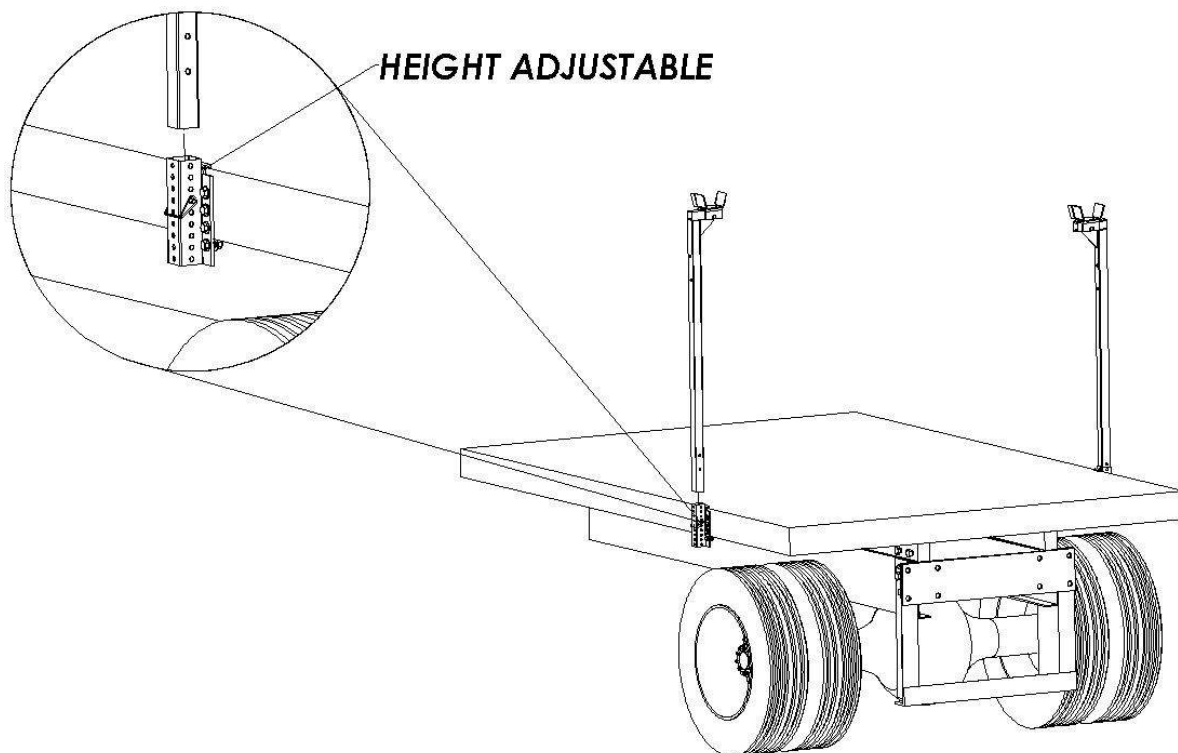

3. To mount the front support angle, position the angle to where the inside surfaces of the angle face away from the flat bed. Align the hole on one end of the front support angle with the hole on the support post, which is the second hole down from the top of the post. Insert a 1/2" bolt to fasten one side of the front support angle, as shown in this image.

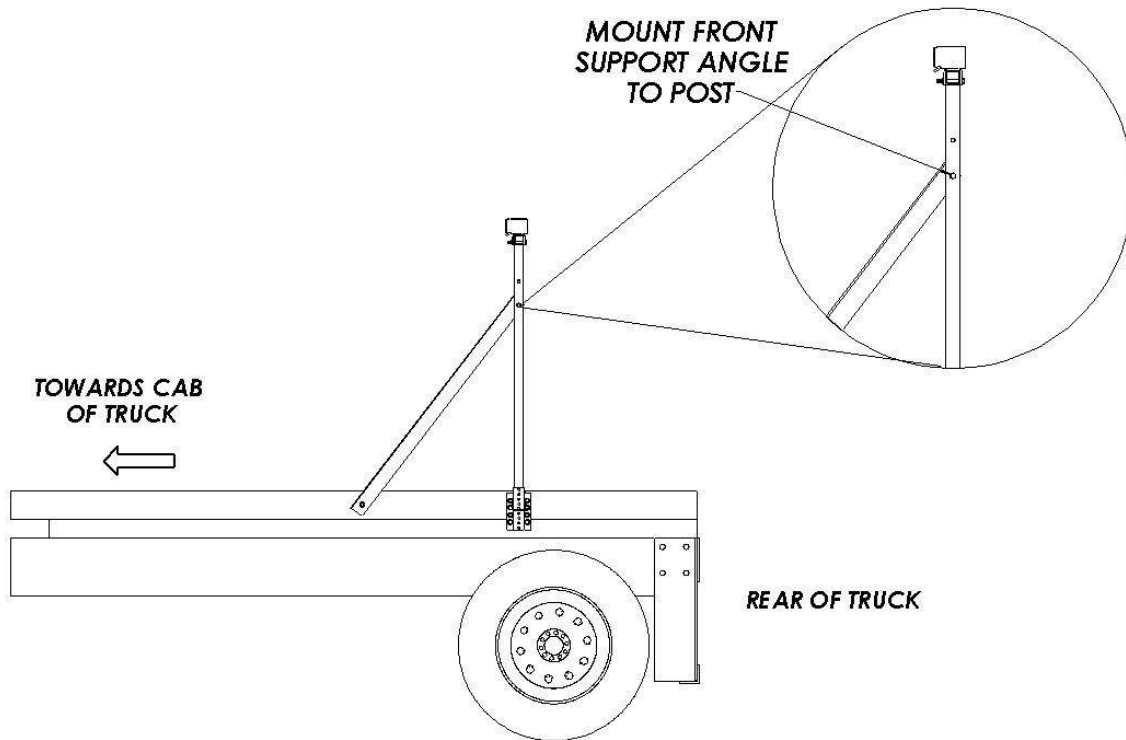

4. Pivot the front angle towards the cab of the truck. Mark and drill another hole into the flat bed and securely fasten the front support angle in place, as shown in the following figure.

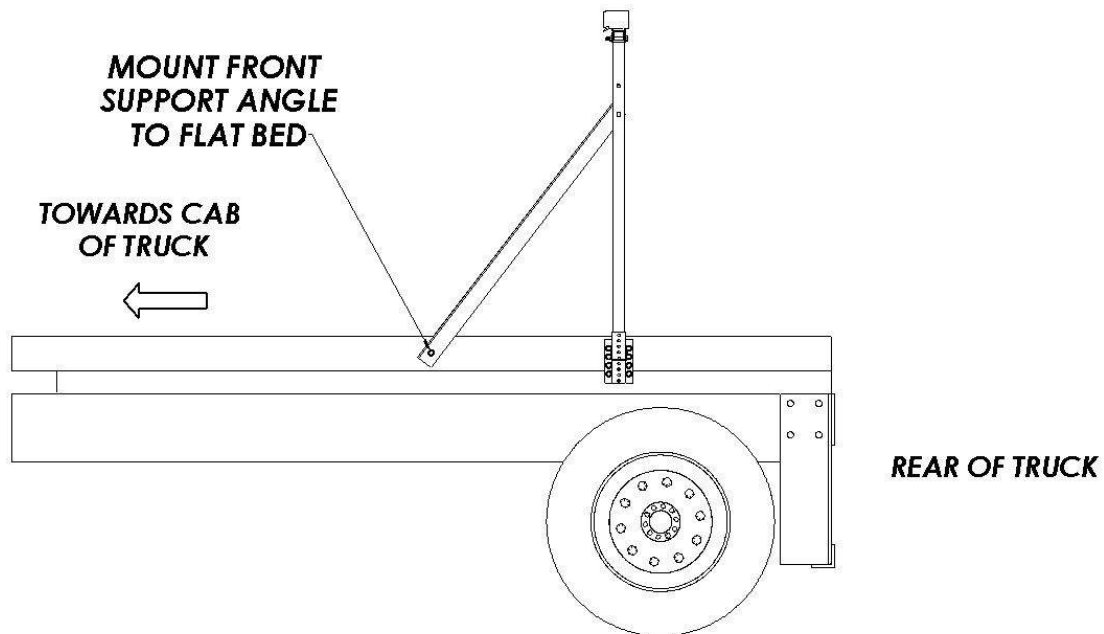

5. Mount the rear support angle to the side support post, with the inside faces of the angle facing outward in the same direction as the front support angle. Pivot the rear support angle towards the rear of the truck, and mark the hole to drill and mount the rear support angle to the bed of the truck. The figure below specifies each location to mount the rear support angle.

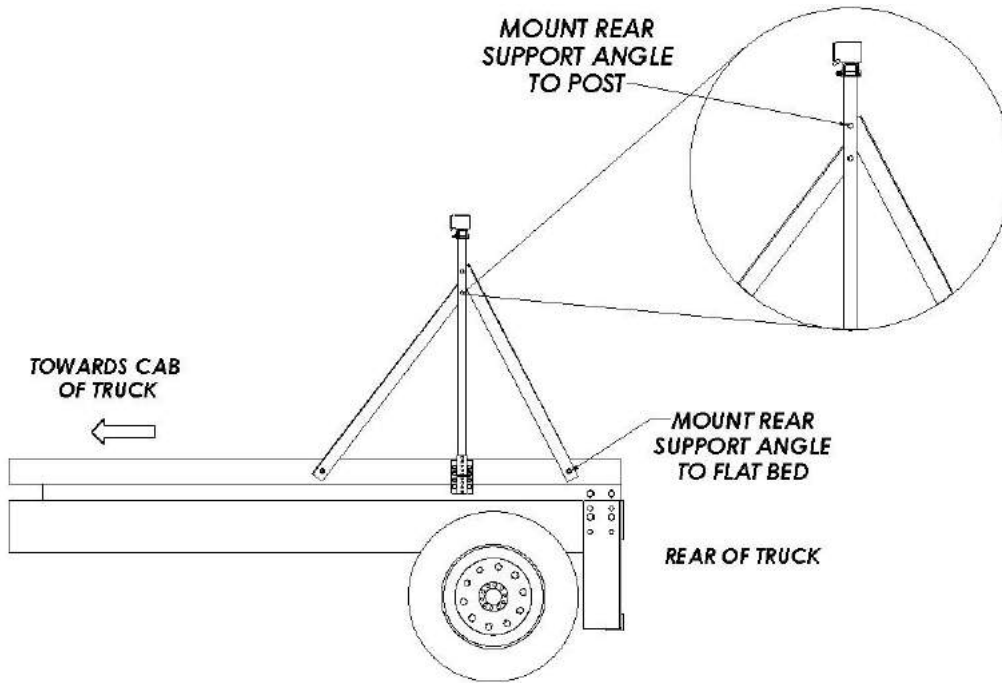

6. When the TMA is raised to the stored position, the wear plates that are mounted onto the top half of the Cartridge tubes (already mounted onto TMA) should align and rest upon the top support post saddles (P/N 11040C) as shown in the figure below.

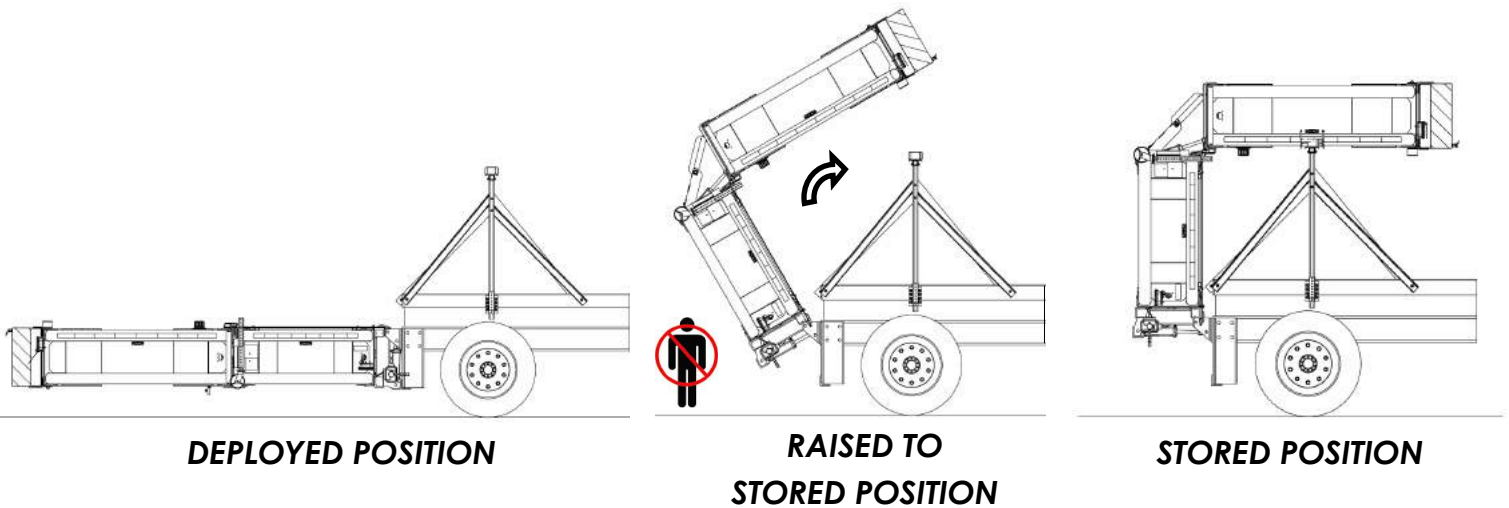



# FLAT BED SIDE SUPPORT COMPLETE ASSEMBLY

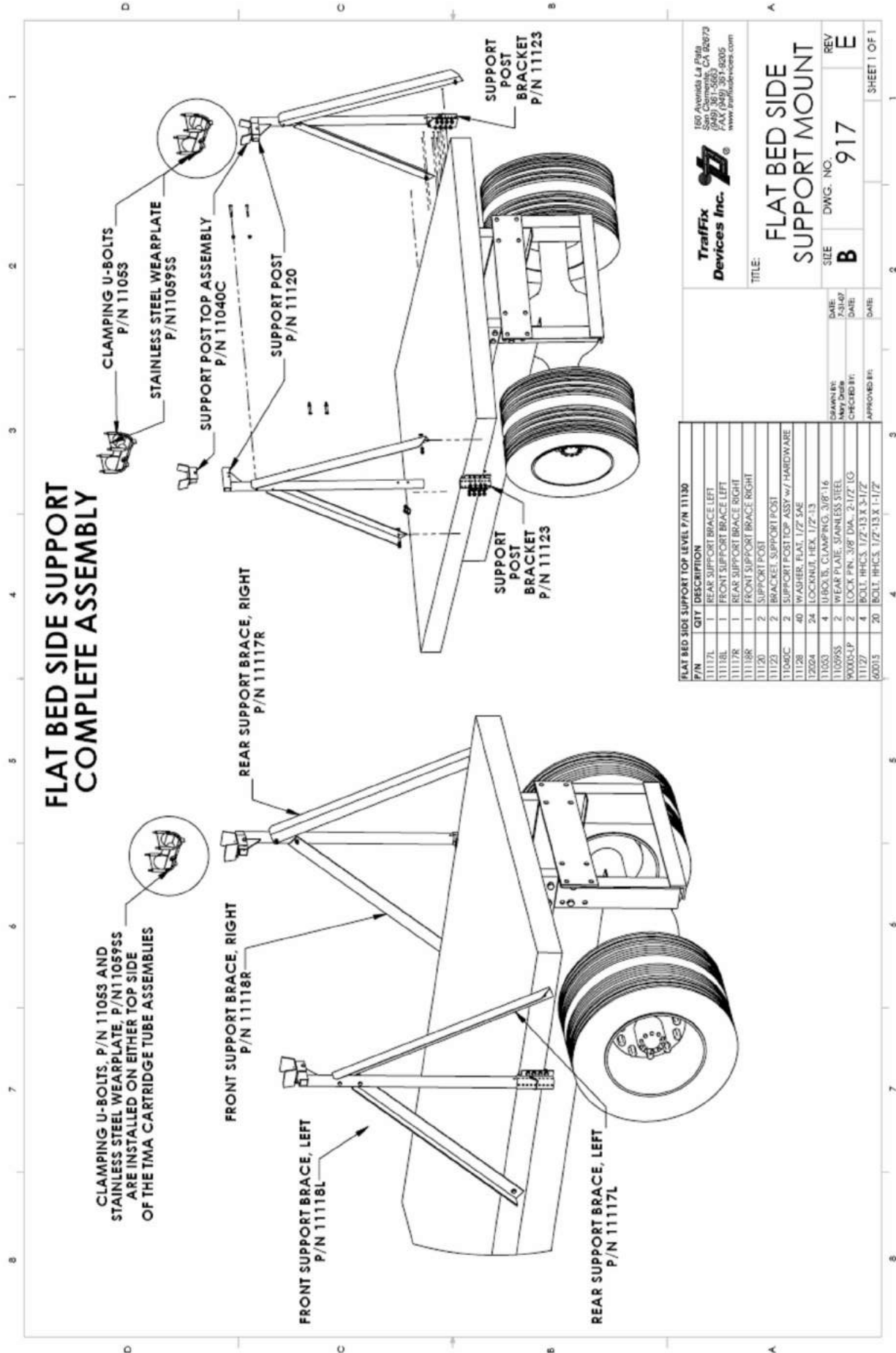

CLAMPING U-BOLTS, P/N 11053 AND STAINLESS STEEL WEARPLATE, P/N 11059SS ARE INSTALLED ON EITHER TOP SIDE OF THE TMA CARTRIDGE TUBE ASSEMBLIES

P/N	QTY	DESCRIPTION
11117L	1	REAR SUPPORT BRACE LEFT
11118L	1	FRONT SUPPORT BRACE LEFT
11117R	1	REAR SUPPORT BRACE RIGHT
11118R	1	FRONT SUPPORT BRACE RIGHT
11120	2	SUPPORT POST
11123	2	BRACKET SUPPORT POST
11040C	2	SUPPORT POST TOP ASSY w/ HARDWARE
11128	40	WASHER, FLAT, 1/2" SAE
12024	24	LOCKWRENCH, HEX, 1/2"-13
11050	4	U-BOLTS, CLAMPING, 3/8" x 16
11059SS	2	WEAR PLATE, STAINLESS STEEL
90005-LP	2	LOCK PIN, 3/8" DIA., 2-1/2" LG
11127	4	BOLT, HHCS, 1/2"-13 X 3-1/2"
60015	20	BOLT, HHCS, 1/2"-13 X 1-1/2"

Trafix Devices Inc.   
 150 Avenida La Plata  
 San Jose, CA 95131  
 (408) 361-5665  
 FAX (408) 361-9005  
 www.trafixdevices.com

TITLE: **FLAT BED SIDE SUPPORT MOUNT**  
 SIZE: **B** DWG. NO.: **917** REV: **E**  
 DATE: 7-31-07  
 CHECKED BY: MVD/DBB  
 APPROVED BY: \_\_\_\_\_

# Center Support Installation



# Center Support Installation

1. To mount the Center Support (P/N 10357) onto the flat bed of the truck, center the base along the width of the truck bed. Figure 1 illustrates the proper location of the center support in reference to the width of the truck. Parts that are used to assemble the center support together are illustrated in the following figure below:

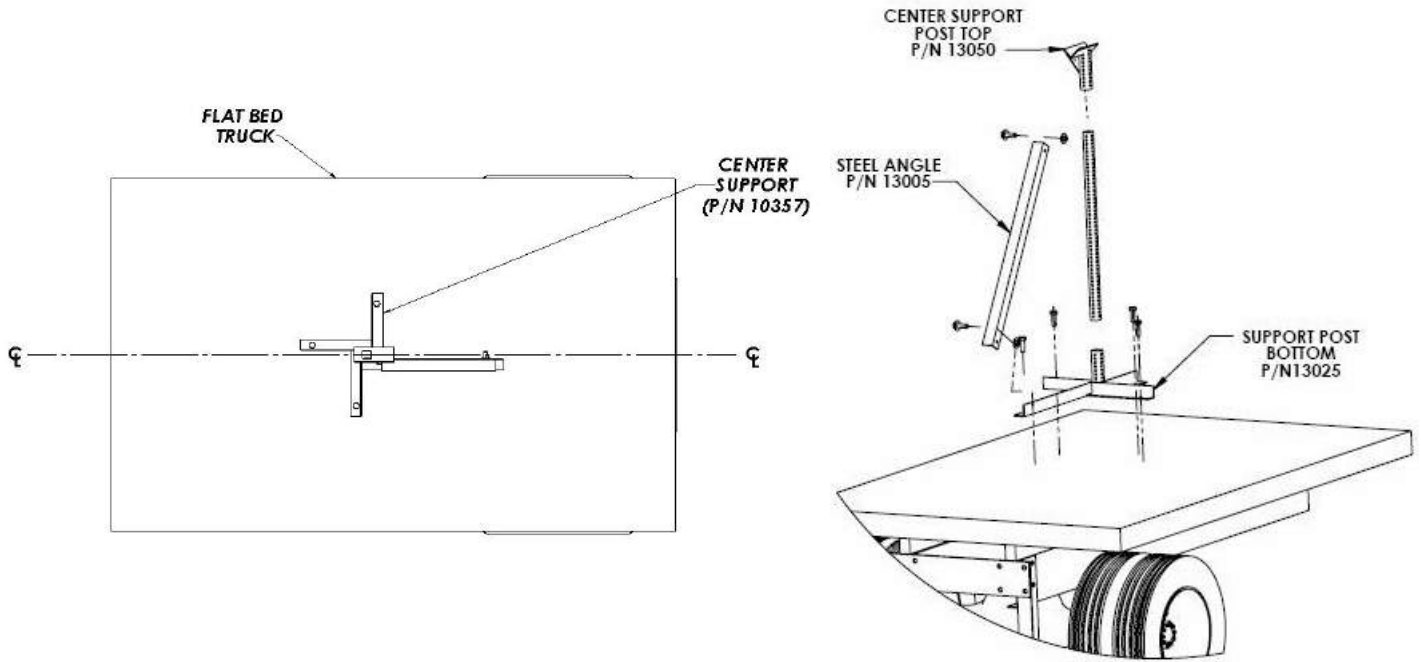

2. Make sure the angle located on the rear cartridge diaphragm aligns with the center support top post angle when the TMA is in the stored position, as shown in this bottom figure.

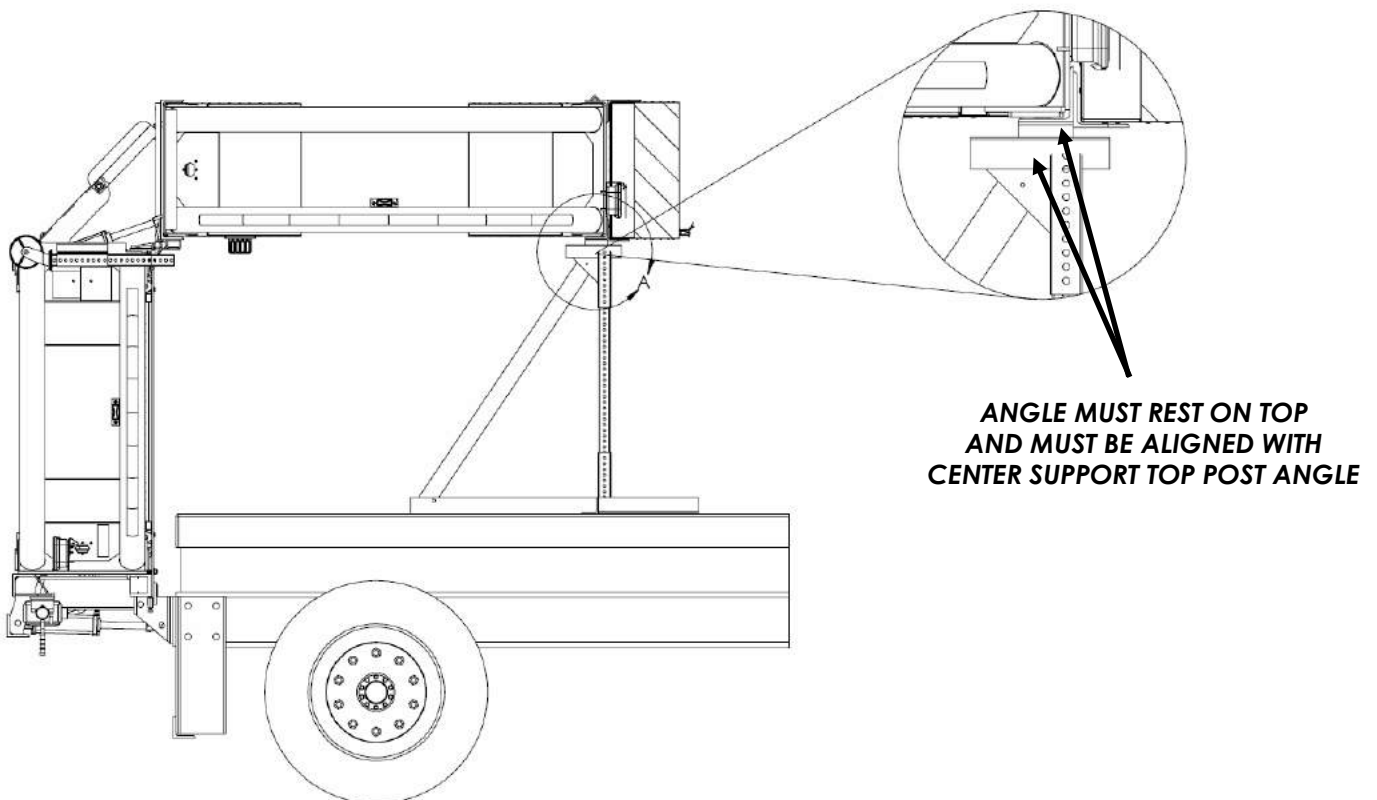

# FLAT BED CENTER SUPPORT COMPLETE ASSEMBLY

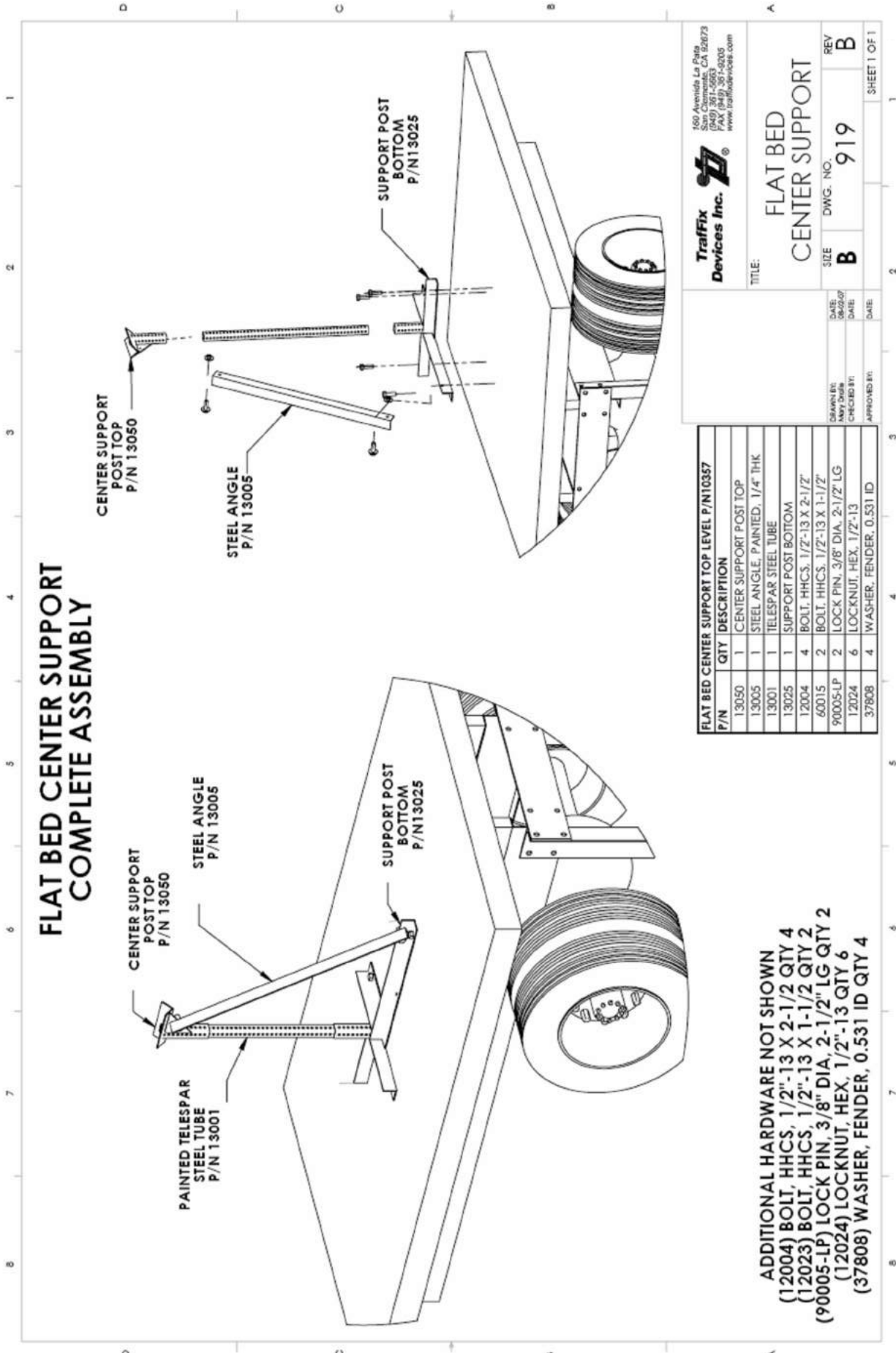

TrafFix  
Devices Inc. 

150 Avenida La Brea  
Covina, CA 91723  
(949) 351-9503  
FAX (949) 351-9205  
www.traffixdevices.com

TITLE:  
**FLAT BED  
CENTER SUPPORT**

SIZE DWG. NO. **B 919** REV **B**

P/N	QTY	DESCRIPTION
13050	1	CENTER SUPPORT POST TOP
13005	1	STEEL ANGLE, PAINTED, 1/4" THK
13001	1	TELESPEAR STEEL TUBE
13025	1	SUPPORT POST BOTTOM
12004	4	BOLT, HHCS, 1/2"-13 X 2-1/2"
60015	2	BOLT, HHCS, 1/2"-13 X 1-1/2"
90005-LP	2	LOCK PIN, 3/8" DIA, 2-1/2" LG
12024	6	LOCKNUT, HEX, 1/2"-13
37808	4	WASHER, FENDER, 0.531 ID

**ADDITIONAL HARDWARE NOT SHOWN**  
 (12004) BOLT, HHCS, 1/2"-13 X 2-1/2 QTY 4  
 (12023) BOLT, HHCS, 1/2"-13 X 1-1/2 QTY 2  
 (90005-LP) LOCK PIN, 3/8" DIA, 2-1/2" LG QTY 2  
 (12024) LOCKNUT, HEX, 1/2"-13 QTY 6  
 (37808) WASHER, FENDER, 0.531 ID QTY 4

# Dump Truck Side Support Installation



# Dump Truck Side Support Installation

1. Mount the support post brackets (P/N 11050) on each side of the dump truck. Mark the position of the holes for the 1/2" bolts and drill these holes in the sides of the dump truck to fasten the support bracket into place. The outer lip portion of the bracket should rest on the topline of the dump truck. The following figure shows how the bracket should be mounted onto the dump portion of the truck.

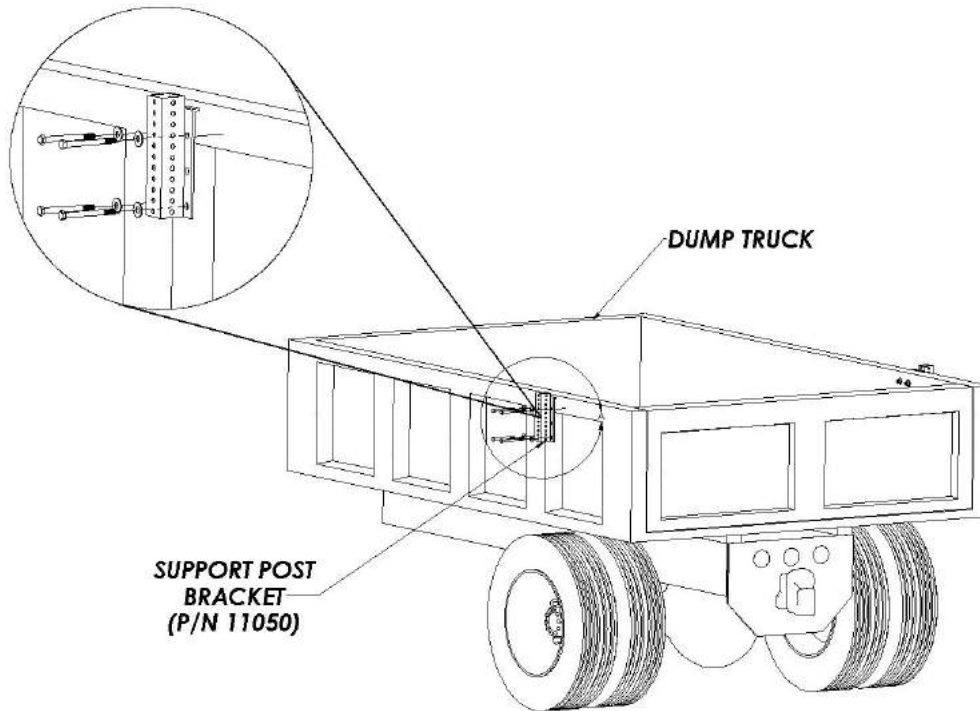

2. Insert the support post (P/N 11055NJ) into the support bracket. Adjust the post to the appropriate height, which will vary based on the height of the dump truck of the host vehicle, to where the cartridge tubes will be able to rest on the support post top saddle when the TMA is in the stored position. This figure below illustrates how the support posts can be adjusted upon installation.

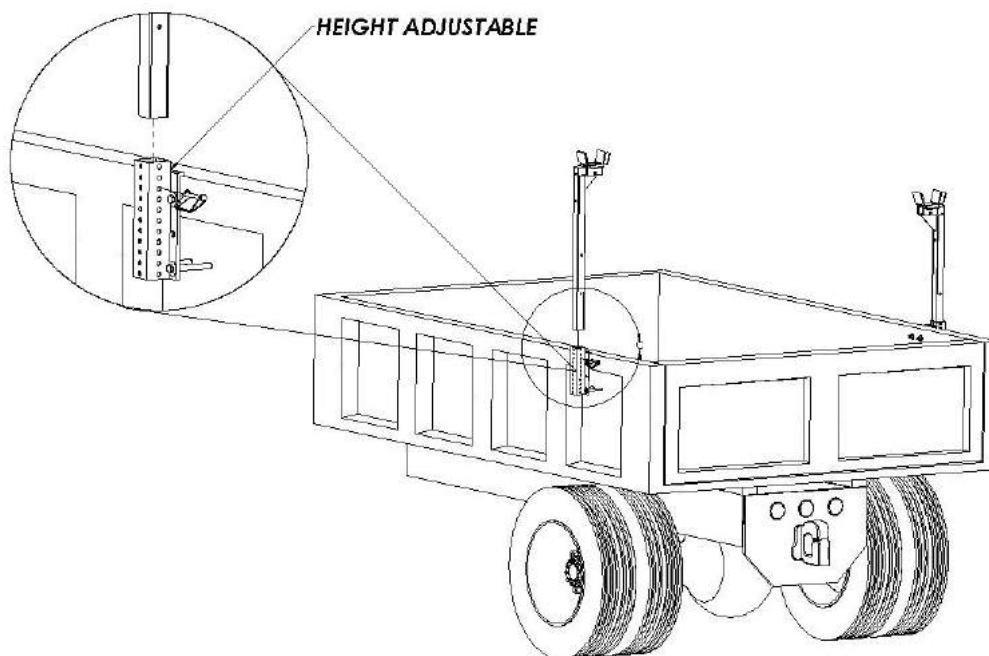

3. To mount the support brace (11057L/11057R), position the brace to where the inside surfaces of the brace face inwards to the truck. Align the hole on one end of the support brace with the hole on the support post. Insert a 1/2" bolt to fasten one side of the support brace, as shown in following figure:

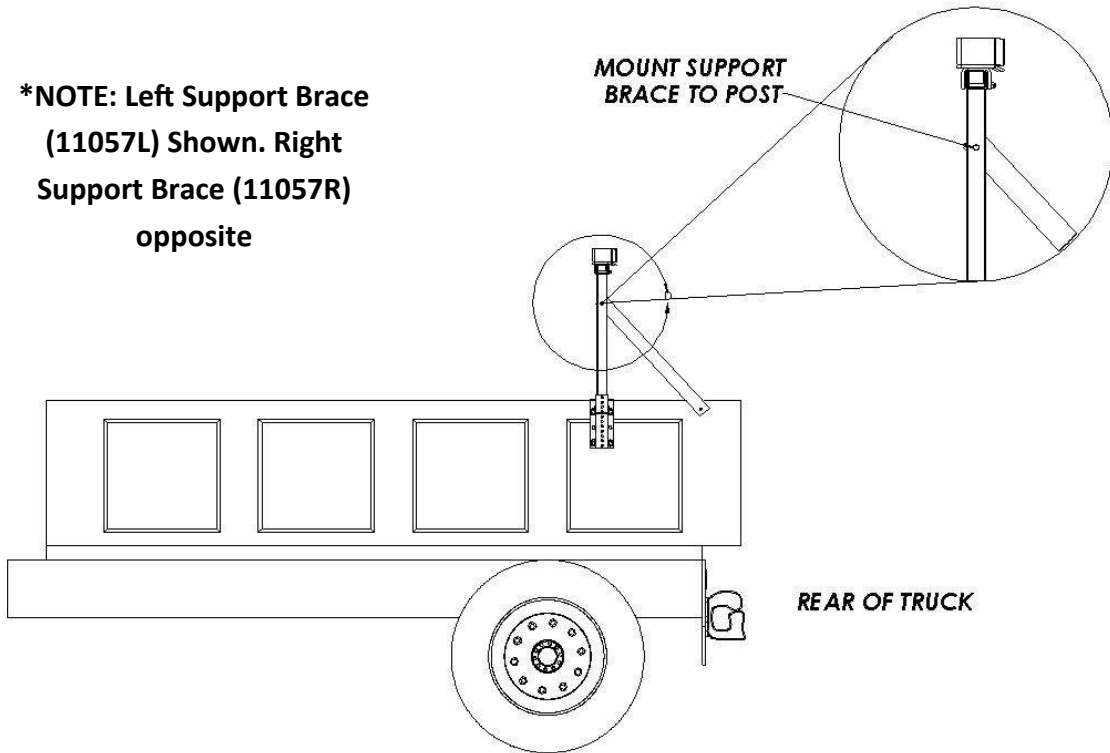

4. Pivot the support brace towards the rear end of the truck. Mark and drill another hole into the dump truck and securely fasten the brace in place, as shown in the figure below.

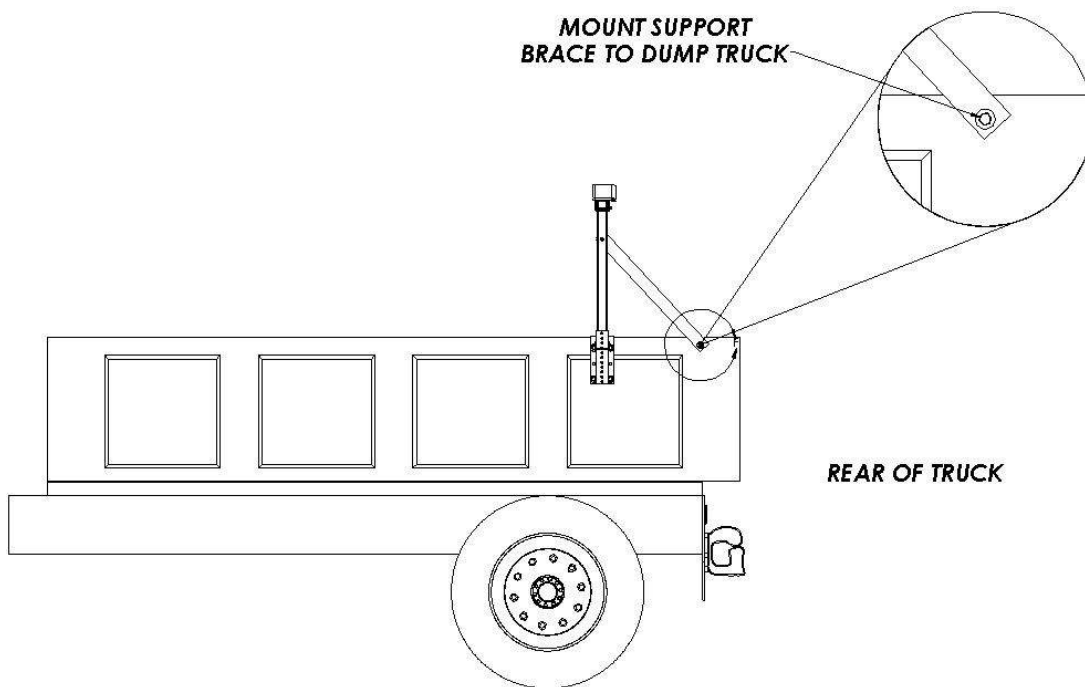

5. When the TMA is raised to the stored position, the wear plates that are mounted onto the top half of the cartridge tubes (already mounted onto TMA) should align and rest upon the top support post saddles (P/N 11040C) as shown in this figure below.

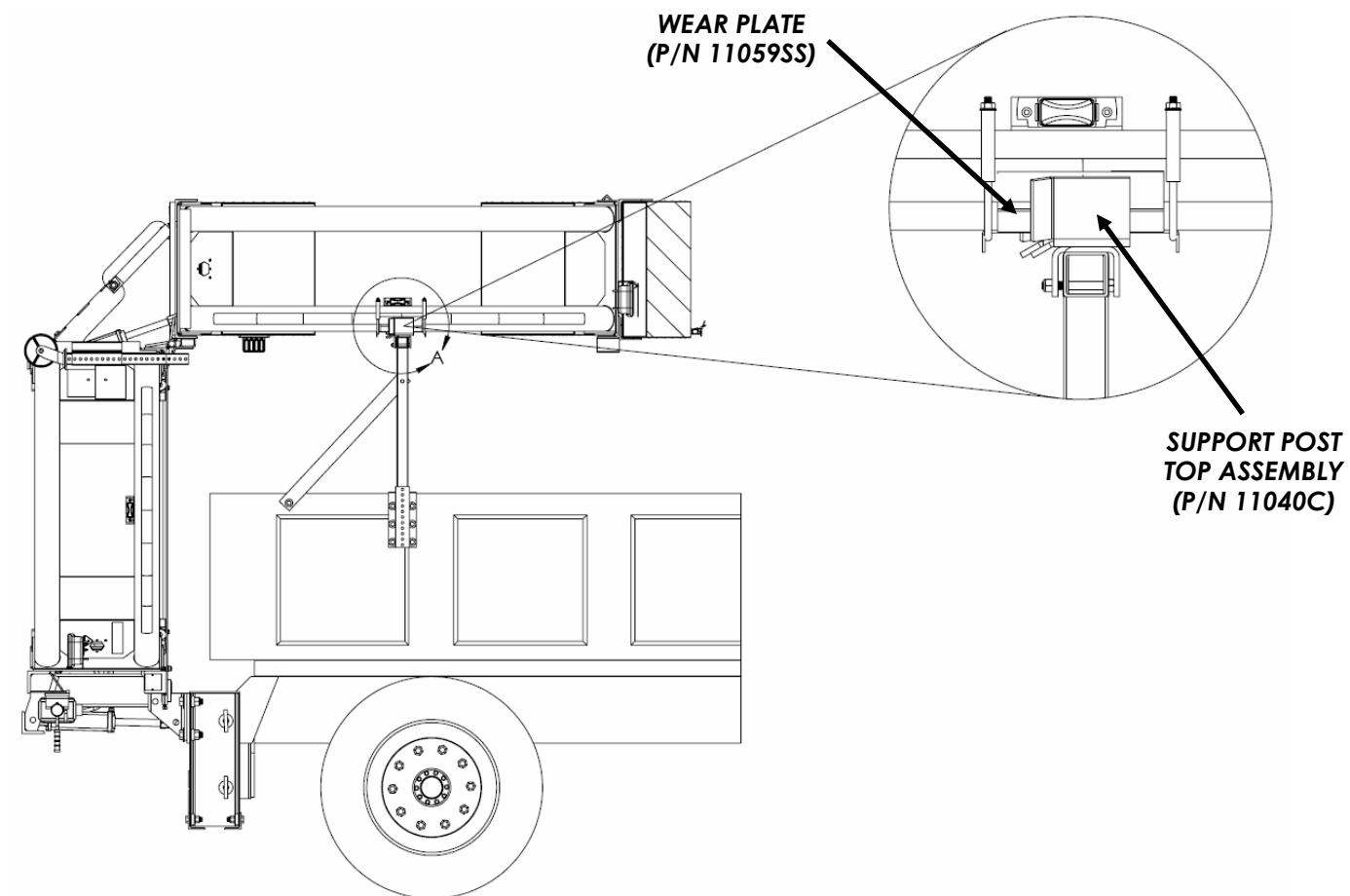

**STORED POSITION**



# DUMP TRUCK SIDE SUPPORT COMPLETE ASSEMBLY

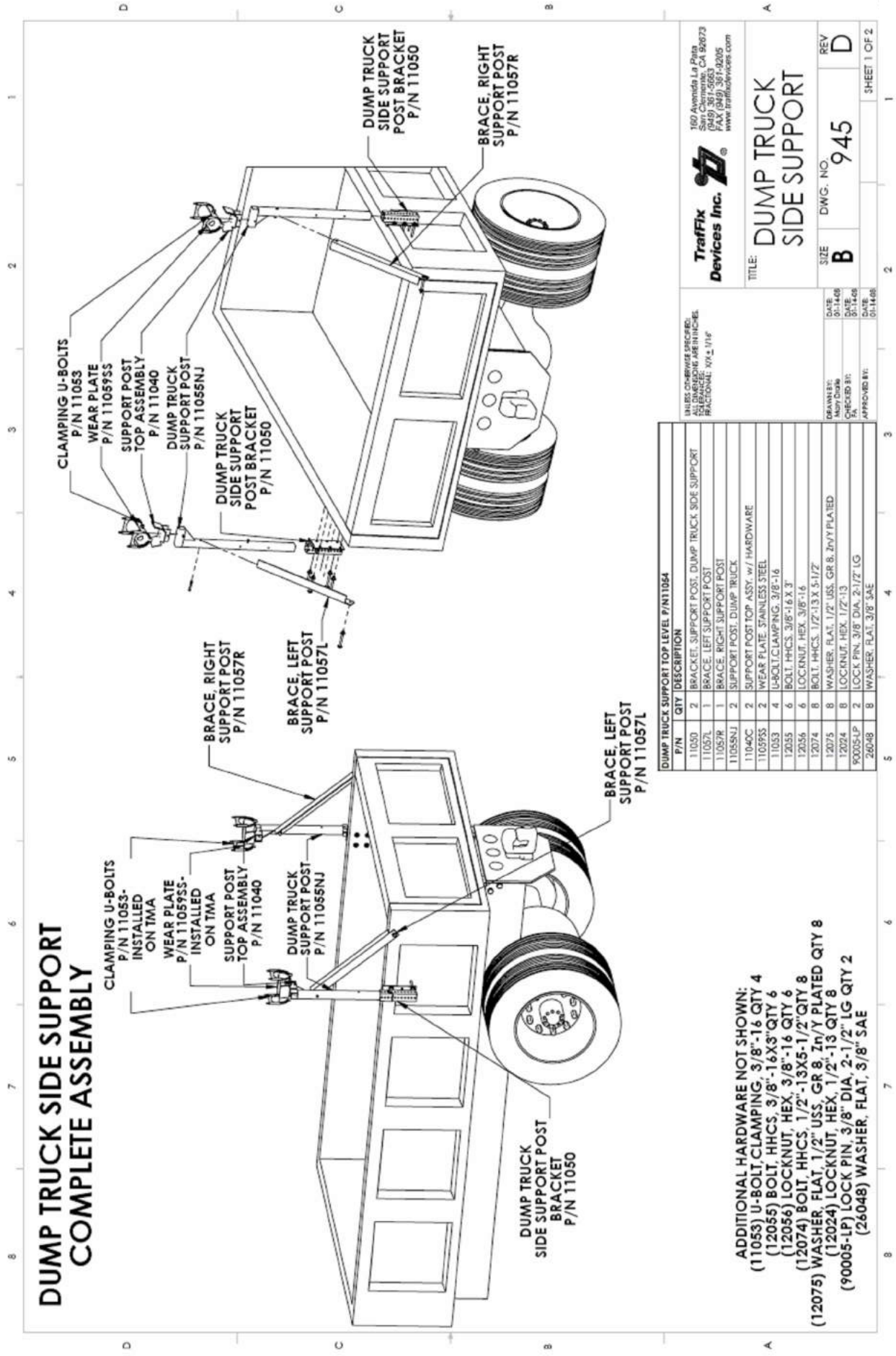

TRAFFIX INCORPORATED  
 160 Avenida La Plata  
 San Clemente, CA 92673  
 (949) 381-0583  
 FAX: (949) 381-0295  
 www.traffixdevices.com

TITLE: **DUMP TRUCK SIDE SUPPORT**

SIZE: **B** DWG. NO: **945** REV: **D**

UNLESS OTHERWISE SPECIFIED:  
 DIMENSIONS ARE IN INCHES  
 FRACTIONAL: 1/16"

DATE: 01-14-08  
 DRAWN BY: MJD/DAW  
 DATE: 01-14-08  
 CHECKED BY: MJD/DAW  
 DATE: 01-14-08  
 APPROVED BY: MJD/DAW  
 DATE: 01-14-08

P/N	QTY	DESCRIPTION
11050	2	BRACKET, SUPPORT POST, DUMP TRUCK, SIDE SUPPORT
11057L	1	BRACE, LEFT SUPPORT POST
11057R	1	BRACE, RIGHT SUPPORT POST
11055NJ	2	SUPPORT POST, DUMP TRUCK
11040C	2	SUPPORT POST TOP ASSY. w/ HARDWARE
11059SS	2	WEAR PLATE, STAINLESS STEEL
11053	4	U-BOLT CLAMPING, 3/8"-16
12055	6	BOLT, HHCS, 3/8"x1.6 X 3"
12056	6	LOCKNUT, HEX, 3/8"x1.6
12074	8	BOLT, HHCS, 1/2"x1.3 X 5-1/2"
12075	8	WASHER, FLAT, 1/2" USS, GR 8, Zn/Y PLATED
12024	8	LOCKNUT, HEX, 1/2"x1.3
90005LP	2	LOCK PIN, 3/8" DIA, 2-1/2" LG
26048	8	WASHER, FLAT, 3/8" SAE

ADDITIONAL HARDWARE NOT SHOWN:  
 (11053) U-BOLT, CLAMPING, 3/8"-16 QTY 4  
 (12055) BOLT, HHCS, 3/8"-1.6 X 3" QTY 6  
 (12056) LOCKNUT, HEX, 3/8"-16 QTY 6  
 (12074) BOLT, HHCS, 1/2"-1.3 X 5-1/2" QTY 8  
 (12075) WASHER, FLAT, 1/2" USS, GR 8, Zn/Y PLATED QTY 8  
 (12024) LOCKNUT, HEX, 1/2"-1.3 QTY 8  
 (90005-LP) LOCK PIN, 3/8" DIA, 2-1/2" LG QTY 2  
 (26048) WASHER, FLAT, 3/8" SAE

## TMA Limited Warranty

TraFFix Devices warrants to the purchaser that the Scorpion II Truck Mounted Attenuator (TMA) is free from any defects in materials and workmanship. If this product proves to be defective in material or workmanship during the period of this warranty, TraFFix Devices will repair or replace, at its option, the defective product free of charge. The period of this warranty is the one year period beginning from the date the purchaser puts the unit into service or one year from the date of purchase.

To obtain warranty service, the purchaser or distributor must first fill out a warranty authorization form and email same to TraFFix Devices to have our technical services department evaluate the problem and recommend repair procedures. **TraFFix Devices will then issue a signed warranty work approval form** to authorize the distributor or customer to repair or replace any items, which TraFFix Devices deems to have been defective. All replacement parts claimed to be defective will be invoiced at the time of shipment, and upon receipt and evaluation a credit memo will be issued.

This warranty does not extend to any failure of the Scorpion II TMA caused by misuse, abuse or material alteration of this product, or any negligence in connection with the installation, service, or use of this product. For the correct installation, service, or use of this product refer to the installation manual, the operator's deployment instructions, and the operator's checklist.

### Warranty Authorization Form

Company Name \_\_\_\_\_

Address \_\_\_\_\_

Phone/E-Mail \_\_\_\_\_

Name of Customer \_\_\_\_\_

Date \_\_\_\_\_

Serial number of TMA near controller outlet: \_\_\_\_\_

List part numbers of replacement or repair items:

\_\_\_\_\_

\_\_\_\_\_

\_\_\_\_\_

9. Describe the problem and reason for failure: \_\_\_\_\_

\_\_\_\_\_

\_\_\_\_\_

10. Email this form with any pictures. Then phone TraFFix Devices technical services.

Phone: (949) 361-5663

E-mail: [orders@traffixdevices.com](mailto:orders@traffixdevices.com)



# Important Contact Information

## Corporate Office

### [Traffix Devices, Inc.](#)

160 Avenida La Pata  
San Clemente, CA, 92673  
USA

Email [orders@traffixdevices.com](mailto:orders@traffixdevices.com)

Telephone 949.361.5663

Fax 949.573.9250

## International Sales

### [Brent Kulp](#)

Email [bkulp@traffixdevices.com](mailto:bkulp@traffixdevices.com)

Telephone 949.361.5663

Fax 949.573.9264

### [Larry Hudoff](#)

Email [lhudoff@traffixdevices.com](mailto:lhudoff@traffixdevices.com)

Telephone 954.997.9997

Fax 949.325.6059

## Attenuator Product Specialist

### [Dave Evans](#)

Email [devans@traffixdevices.com](mailto:devans@traffixdevices.com)

Telephone 949.449.7066

## Northeast Territory

VA, WV, DE, MD, DC, NJ, NY, PA, CT,  
MA, RI, NH, VT, ME

### [Mike Herlehy](#)

Email [mherlehy@traffixdevices.com](mailto:mherlehy@traffixdevices.com)

Telephone 585.267.9970

Fax 949.573.9239

## Midwest Territory

OH, MI, IN, KY, IL, WI, MN, ND, SD,  
IA, MO

### [Dave Lindquist](#)

Email [dlindquist@traffixdevices.com](mailto:dlindquist@traffixdevices.com)

Telephone 630.605.1273

Fax 949.573.9240

## Northwest Territory

MT, UT, ID, WA, OR, NV, CO, WY

### [Cary LeMonds](#)

Email [clemonds@traffixdevices.com](mailto:clemonds@traffixdevices.com)

Telephone 801.979.7099

Fax 949.573.9290

## Southwest Territory

TX, OK, KS, NE, NM, AR, LA

### [John Gense](#)

Email [jgense@traffixdevices.com](mailto:jgense@traffixdevices.com)

Telephone 214.704.1476

Fax 949.573.9291

## Western Territory

CA, HI, AK, AZ

### [Rob Snell](#)

Email [rsnell@traffixdevices.com](mailto:rsnell@traffixdevices.com)

Telephone 949.350.7048

Fax 949.573.9267

## Southeast Territory

TN, NC, SC, GA, MS, AL, FL

### [Larry Hudoff](#)

Email [lhudoff@traffixdevices.com](mailto:lhudoff@traffixdevices.com)

Telephone 770.778.8281

Fax 949.325.6059



*160 Ave. La Pata  
San Clemente, California 92673  
(949) 361-5663  
FAX (949) 361-9205  
[www.traffixdevices.com](http://www.traffixdevices.com)*

Distributed By: