

AWVMS

Advance Warning Variable Message Signs

Mid Hinge & Quick Release/ Quick Connect

Proudly Brought to You By:

RTL 



Advance Warning, Improved Safety

The AWWMS is a widely used, increasingly popular piece of kit on NZ roads. It is designed to be a stationary sign that is located on the road shoulder and out of live lanes, replacing the need for a tail pilot TMA vehicle.

NZTA reports significantly improved safety statistics when an AWWMS unit is deployed. It has been reported that approaching motorists easily comprehend the AWWMS notifications and respond rapidly to directional instructions. RTL has been manufacturing high quality AWWMS for over 5 years. We have continuously improved our offer as the technology has developed and grown in NZ. Our AWWMS is fully compliant to NZTA CoPTTM specifications and European Standard EN12966.

Display Boards

Top Panel: Provides advance warning notification

Bottom Panel: Provides directional instructions and single line text

LED Technology

Providing bright, clear images with efficient power consumption and low maintenance cost

Electronic lifting vs Hydraulic lifting

Low maintenance, no oil leaks, lifting system parts are available locally

Galvanised Steel Frame

Designed and engineered in New Zealand for New Zealand conditions

Independently powered

Maintain peak operating performance with daily charging of batteries
Portable, remote generator charging option available

Xenon Lights

Give advance warning to approaching road users
Compliant with EN12352:2006

Automatic/ Manual Light Dimming

LED brightness can be automatically or manually adjusted

Wireless Touch Screen Controller

Pre-programmed with approved symbols that can be loaded at the touch of a button

Configurations

Vehicle, trailer and unit mount options or as individual system components – i.e. the frame, board and lifting system

Lockable Control & Battery Boxes

Provides security and protection from theft

Retro-reflective Panel

300mm high retro-reflective red/ white base panel designed and installed to suit your vehicle



Mid Hinge

Quick Release/Quick Connect

The Mid Hinge AWVMS is a compact, low profile design ideal for high-speed travel on motorways & highways. It stores in the folded position (Fig A) and folds up to 90° when in use (Fig B).

The Quick Release/ Quick Connect feature enables you to maximise the use of your fleet. When the AWVMS is no longer required, simply remove the AWVMS to free up your vehicle for other works. The unit is quickly and safely lifted off the ute deck, using a fork hoist.

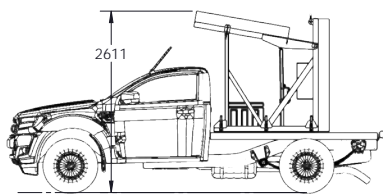
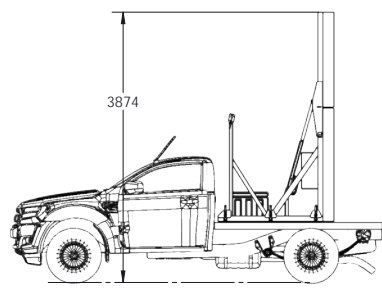

Figure A



Images are indicative only and subject to change

Figure B

Quick Release/Quick Connect

A Base Plate is installed onto the tray of the ute. The Base Plate has four stillage feet, one in each corner. These act as locators for the frame and enable easier placement when positioning the AWVMS frame into place. The unit is locked in place by six locking latches, each latch has a load rating of 800kg.

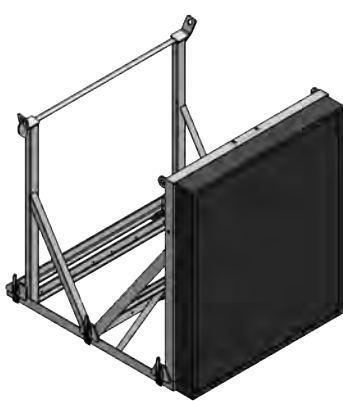

Mid Hinge Frame & Base Plate

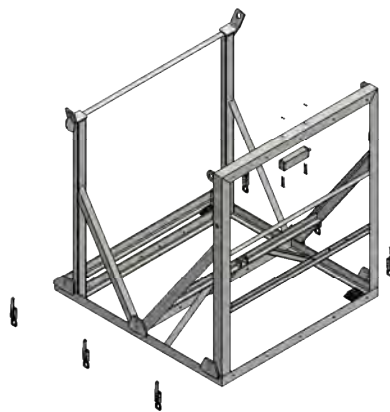

Locking Latches (6)

Safety Message

RTL encourages safe lifting and manual handling practices and advises all customers to ensure all staff are trained in manual handling of heavy goods.



RTL offers several configurations to suit your specific needs

1. Full RTL AWVMS

- Boards (Top & Bottom)
- Frame
- Installation & Commissioning
- Xenon Lights
- Wireless Controller
- LINAK Lifting System
- Batteries

**** RECOMMENDED ****

2. Board Only + Lifting System

- Boards (Top & Bottom)
- Xenon Lights
- Wireless Controller
- LINAK Lifting System
- Batteries

3. Board Only

- Boards Only (Top & Bottom)
- Xenon Lights
- Wireless Controller

Local Knowledge, Local Service & Nationwide Reach

We offer reliable, cost effective, after sales support that is only a phone call away

- 12 Month Warranty
- Extended Warranty Options
- Proactive Solutions & Service
- Onsite Technical Support
- Phone Helpdesk
- Preventative Maintenance Plans
- User Training
- Extensive Knowledge Base

Call Us for expert advice

0800 785 744



www.rtl.co.nz

Auckland

Wellington

Christchurch

Invercargill