

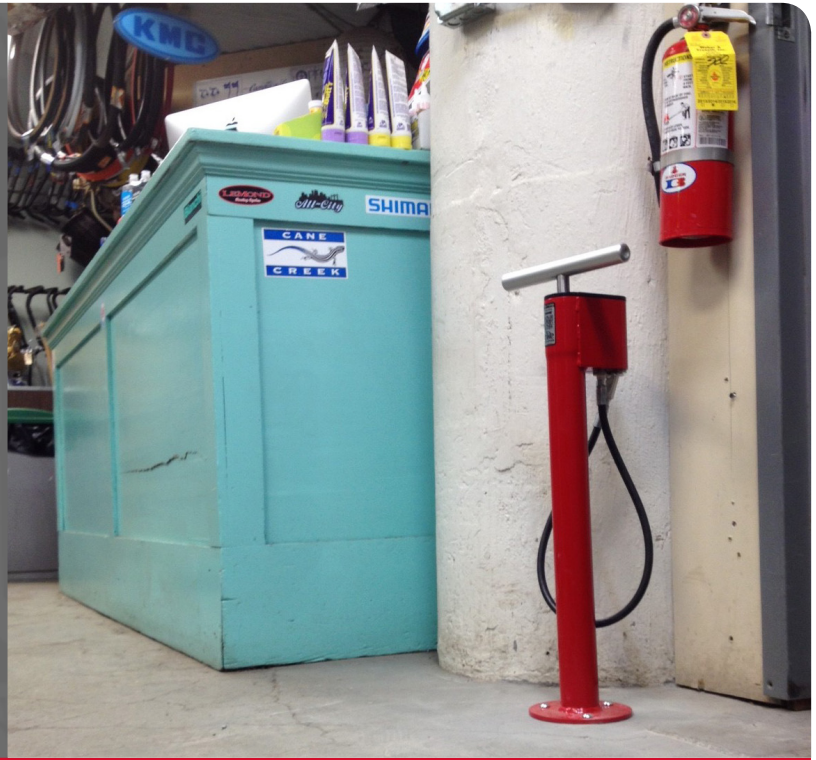

INDOOR PUMP

The High Security Indoor Pump is a perfect shared-use bike pump for inside installation. It is ideal for bike rooms and parking areas. A high quality, solid stainless steel piston rod, alloy handle and smash proof gauge cover provide maximum vandal resistance and durability. Heavy duty, cut-resistant hose and security fittings hold a replaceable pump head that handles both Presta and Schrader valves with ease.



26248 Shown

Product Details

- Solid stainless steel piston rod, alloy handle, and smash proof gauge cover provide maximum vandal resistance
- Hose with braided steel core provides protection against cutting
- Choice of two hose lengths (18" or 35")
- Universal pump head works with Presta and Schrader valves
- 2 year warranty

Specifications

Model #	Finish	Type of Mount	Weight	Length	Width	Height	Space Requirement
26248	Powder Coat	Flange Mount	20 lbs.	8"	8"	30"	See Back
26252	Powder Coat	Repair Stand Mount	20 lbs.	8"	8"	30"	See Back

Our Bike Fixation representatives can assist with custom layout and spacing to meet your room dimensions and desired bike capacity.



Indoor Pump

Recommended Spacing

The minimum space requirements for High Security Bike Pumps are meant to allow a cyclist and their bike access to the pump.

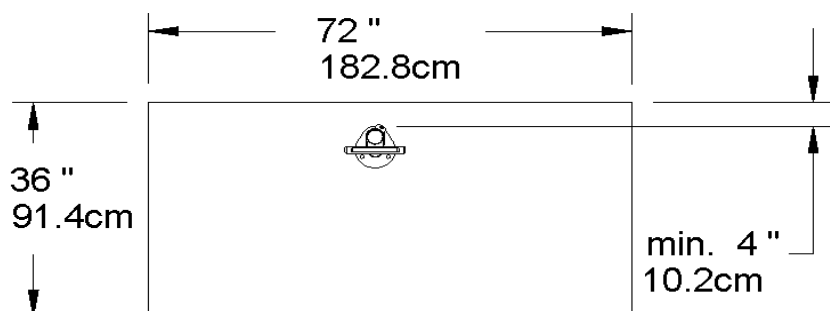

Manufactured by Bike Fixation

Product Information



???

of Bikes



Powder coat

Materials



Installation hardware included

Finish



Made in the USA



2 year warranty



Standard Colors

Proudly Brought to You By:



0800 785 744

rtl.co.nz

Downloadable product resources available online:



CAD Files



SketchUp Files



Written Specs



Photos